



**HOME OWNERS MANUAL**  
**HUD MANUFACTURED HOME**

**Fairmont Homes, Inc.**  
**P.O. Box 27**  
**Nappanee, Indiana**  
**46550**  
[www.fairmonthomes.com](http://www.fairmonthomes.com)

# Contents

INTRODUCTION.....1  
IMPORTANT AIR QUALITY INFORMATION.....2  
WARRANTY & DISPUTE RESOLUTION.....3  
EXTERIOR MAINTENANCE.....8  
INTERIOR MAINTENANCE.....11  
HOME SAFETY FEATURES.....15  
INSURANCE.....22  
SPECIAL INFORMATION.....24  
INDEX.....37

**RADCO  
REVIEWED  
DATE  
10/22/2008**

# **INTRODUCTION**

## **1-1 A SPECIAL WORD TO THE HOMEOWNER**

The National Manufactured Home Construction and Safety Standards Act of 1974 was enacted to improve the quality and durability of manufactured homes and to reduce the number of injuries and deaths caused by manufactured home accidents. The federal manufactured home construction and safety standards issued under the Act govern how manufactured homes must be constructed. Your manufactured home was manufactured to the standards. The standards cover the planning and construction of your home. They were developed so that you would have a safe, durable home. The standards do not cover such aspects of a manufactured home as furniture, carpeting, and certain appliances, cosmetic features of the home, and additional rooms or sections of the home that you have added.

The Act provides that if, for some reason, your manufactured home is found not to meet the standard or to contain safety hazards, the manufacturer of the manufactured home must notify you of that fact. In some cases where there is a safety hazard involved, the Act requires the manufacturer to correct the manufactured home at no cost to you or to replace the home or refund all or a percentage of the purchase price. If you believe you have a problem for which the Act provides a remedy, you should contact the manufacturer, the manufactured home agency in your state (see the list on pages 28-30 of this manual), or the Department of Housing and Urban Development. Our address is printed on the front cover of this manual. We recommend that you contact us first because that is the quickest way to have your concern considered.

## **1-2 NOTICE TO THE HOMEOWNER**

Please be advised that this company does not participate in retail sales. Our homes are purchased by independent retailers, who in turn sell them to their customers. We, of course, have no control over, and are not aware of the terms and conditions of these sales, nor the manner in which these homes and home sites are prepared for final installation of the homes. In like manner, we have no control or obligation in matters concerning after market items, such as installation, skirting, appliances and/or furnishings not on the factory invoice, porches, decks, awnings, ramadas, concrete work, utility connections, etc.

To keep the home in compliance with its warranty, the home installation must follow the procedures described in the installation manual provided with the home or other procedures approved by the manufacturer. Deviation from the instructions in the manual may void the home's warranty. Any alterations or changes to the home should be designed by a registered professional engineer or registered architect and may still be subject to warranty violations.

# IMPORTANT AIR QUALITY INFORMATION

## 2-1 LIMITED AIR CHANGE AND LIMITED AIR VOLUME

Your new home is energy efficient, and the HUD Standards under which it was constructed limit the air infiltration around windows, ceilings, etc. As a consequence, air exchange is generally less than in an older, draftier, larger home. Further, space is efficiently used, and total air volume of your home may be less than in an older or large home you have lived in.

Some people, because of special health considerations, may require additional air exchange to feel comfortable breathing. This can be obtained by cracking windows or having energy efficient air exchange system installed. People with allergies, emphysema, asthma, oxygen deficiencies, or the like should make certain that they are providing adequate fresh air through the provided ventilation, windows, or other systems necessary to eliminate stale air.

## 2-2 AIR POLLUTANTS

All habitations of human beings have some degree of air pollutants. Your home had a warning label concerning formaldehyde installed on the counter top at the factory as required by the Department of Housing and Urban Development. There are numerous other pollutants in home atmospheres caused by cooking, cleaning chemicals, paints, varnishes, plastics, smoking, clothing, etc., and ingredients in various manufactured products. Proper ventilation by the home owner reduces the level of these pollutants in home atmospheres.

If any persons living in your home do not have a sense of well-being in the home or have a chronic problem, inadequate air exchange should immediately be suspected and the home owner should take immediate steps to provide additional air exchanges. Your retailer will be willing to install additional equipment for a reasonable charge if you require additional ventilation and object to ventilation through cracked windows.

## 2-3 IMPORTANT HEALTH NOTICE

Some of the building materials used in this home emit formaldehyde. Eye, nose, and throat irritation, headache, nausea, and a variety of asthma-like symptoms, including shortness of breath, have been reported as a result of formaldehyde exposure. Elderly persons and young children, as well as anyone with a history of asthma, allergies, or lung problems may be at greater risk. Research is continuing on the possible long term effects of exposure to formaldehyde.

Reduced ventilation resulting from energy efficiency standards may allow formaldehyde and other contaminants to accumulate in the indoor air. Additional ventilation to dilute the indoor air may be obtained from a passive or mechanical ventilation system offered by the manufacturer. Consult your retailer for information about the ventilation options offered with this home.

High indoor temperature and humidity raise formaldehyde levels. When a home is to be located in areas subject to extreme summer temperatures, an air-conditioning system can be used to control indoor temperature levels. Check the comfort cooling certificate to determine if the home has been equipped or designed for the installation of an air-conditioning system.

If you have any questions regarding the health effects of formaldehyde, consult your doctor or local health department.

## 2-4 ATTENTION HOMEOWNERS

The Federal Manufactured Home Construction and Safety Standards Act of 1974 requires every producer of manufactured homes to provide a booklet with at least three detachable information cards with each home. We need the information which these cards, when completed and mailed, will supply. **If you bought your home from a home retailer, please be sure that your home retailer has completed and mailed a card for you.** If you acquired your home from someone who is not a home retailer, you should promptly fill out and send a card to this company. It is important that you keep this booklet and give it to any person who buys the manufactured home from you.

# WARRANTY & DISPUTE RESOLUTION

## 3-1 WARRANTY

### FAIRMONT HOMES, INC. ONE YEAR LIMITED WARRANTY.

**For Your Protection And Understanding, Read All Parts Of This Warranty And Other Warranties  
Furnished With This Home.**

Serial Number: \_\_\_\_\_.

#### 1. What is Covered

A new Fairmont Homes, Inc. ("Fairmont") home has a limited warranty provided by Fairmont to the initial retail purchaser and subsequent purchasers ("Purchaser") as provided herein. Specifically, the structural components and installation of the electrical and plumbing systems of the Home as listed in Section 1 are warranted to the purchaser when sold to the initial retail purchaser by an authorized Fairmont retailer ("Retailer") to be free from manufacturing defects in materials and workmanship under normal use and service, for a period of one year which period starts on the date the initial purchaser takes delivery of the Home. This limited warranty covers only those defects that occur or exist within the applicable period referenced above and which are specifically identified to Fairmont in the manner specified in Section 4 of this Limited Warranty. **All obligations of Fairmont pursuant to this Limited Warranty are limited to replacing or repairing the defective part or component in accordance with the Fairmont Specifications/Performance Guidelines Booklet, a copy of which can be obtained from an authorized Retailer, or by requesting one in writing from the Aftermarket Service Manager, Fairmont Homes, Inc, P. O. Box 27, Nappanee, IN, 46550.**

This limited structural components and installation warranty covers the following structural member installations: Roof rafters and framing – Metal roofs and shingle roofs except wind or storm damage ordinarily covered by insurance, and other acts of God – Sidewall studs and sidewall framing – Floor decking and floor joists (not including floor coverings or carpeting) (Purchaser must not allow water to stand on floor) – Frame under normal usage, properly blocked and when manufactured weight not added to in transit – Exterior sheet metal –

Installation by Fairmont of plumbing in-floor or in-wall or in-roof distribution system (other than faucet leaks and normal waste stoppage) – Installation by Fairmont of electrical in-floor or in-wall or in-roof distribution system (assuming it has been properly hooked up, is not overloaded, and has not been modified or tampered with) (appliances not warranted by Fairmont) – In-floor or in-wall water leaks (other than those caused by transit or improper set up) – ATTENTION: Fairmont is not liable for damages or defects caused during installation of the Home on the home site or that occur during transportation, by acts of God, or by damage or defects caused by use of the home as a moving van for weights exceeding original delivery weight, or caused by improper foundation or the lack of, or improper alignment, and the lack of, or improper maintenance.

#### 2. DISCLAIMER OF WARRANTIES

**This Limited Warranty is expressly IN LIEU of any other express warranty and is further IN LIEU of any implied warranty, including, but not limited to, any implied WARRANTY OF MERCHANTABILITY or FITNESS FOR A PARTICULAR PURPOSE. To the extent that applicable state and/or federal law prohibits the exclusion of any remedy permitted under state or federal law, any such remedy, including but not limited to implied warranties of FITNESS, USE, MERCHANTABILITY OR PURPOSE, are limited to one (1) year from the date the initial retail purchaser takes delivery of the Home. There are no warranties which extend beyond description on the face hereof.**

#### 3. WHAT ARE THE AUTHORIZED RETAILER'S OBLIGATIONS

It is the responsibility of the Retailer to maintain the Home until retail sold to the initial purchaser; to perform a comprehensive pre-retail delivery check procedure and inspection; to repair or replace any defective parts; to correct defects in workmanship which are identified prior to initial purchaser's taking delivery of the Home; to present the initial retail purchaser with this Limited Warranty prior to the initial retail purchaser's entering into any written contract to purchase a home; and to mail Fairmont the signed Warranty registration card and the signed Limited Warranty.

#### 4. WHAT ARE THE PURCHASER'S OBLIGATIONS

Proper care and maintenance by the Purchaser is necessary to preserve the Home's fitness for habitation. The purchaser is responsible for all maintenance as described in the Fairmont Home Owners Manual and/or other care and maintenance manual supplied with the Home. Minor adjustments (such as adjustments to the interior or exterior doors, cabinet doors, etc.) are the responsibility of the purchaser as normal maintenance unless required as a direct result of repair or replacement of a defective part under this Limited Warranty.

If any issue occurs which the Purchaser believes is covered by this Limited Warranty, the Purchaser is responsible to promptly contact Fairmont in writing in the following manner:

- a. Describe the part or feature of the Home that is affected;
- b. Describe the problem with that part or feature;
- c. State the date that this problem or defect was first observed;
- d. Describe the circumstances surrounding the observation of the problem or defect;
- e. State your address, if different, the address of the home, together with your daytime and evening phone numbers;
- f. Send this description to Fairmont Homes, Inc. by U.S. certified mail, return receipt requested, to the following address: Aftermarket Service Manager, Fairmont Homes, Inc., P. O. Box 27, Nappanee, IN, 46550.

Such notice must be received by Fairmont within the earlier of 30 days after the issue is known to the Purchaser, or ten (10) days subsequent to the expiration of this Limited Warranty. Warranty claims are not registered over the telephone. A Fairmont Representative will contact you to discuss your concerns and arrange for a time to inspect/repair the problem or defect.

Repairs or replacements by Fairmont and/or your Retailer that are required under this Limited Warranty will be made within 30 days after the purchaser notifies Fairmont of those defects as provided above in this section, barring weather and/or any other unforeseeable circumstances. All repairs or replacements that are required by this Limited Warranty will be made at the site of the Home and without charge to the Purchaser.

Fairmont will arrange for repair or replacement, as determined by Fairmont, of Fairmont parts or workmanship identified as defective by Fairmont and such parts replaced shall be the property of Fairmont. The Purchaser is advised that he/she must notify Fairmont of any items believed to require warranty service. Fairmont is ready, willing, and able to make every effort for a quick response. Fairmont reserves the right to cure all warranty claims. Service work conducted by any party not specifically authorized by Fairmont to undertake such work is specifically not covered by this Limited Warranty. Further, failure of the Purchaser to strictly comply with the notification provisions of this section shall release Fairmont from any responsibility for any claims regardless of whether the claim is a tort, contract, equitable or other claim.

The Purchaser must maintain all evidence of any defect or damage through the ultimate resolution of any claim and make such evidence available to Fairmont. Failure to preserve such evidence will VOID ANY CLAIM FOR SUCH DEFECT OR DAMAGE.

#### 5. WHAT IS NOT COVERED BY THIS LIMITED WARRANTY

- **ANY COMPONENT PART WHICH POSSESSES ITS OWN WARRANTY FROM A PARTY OTHER THAN FAIRMONT. AS TO ANY PART, APPLIANCE, OR DEVICE WARRANTED BY ITS MANUFACTURER'S SEPARATE WARRANTY, PLEASE CONTACT THE NEAREST SERVICE CENTER INDICATED IN THE SEPARATE WARRANTY.**
- **THE ITEMS LISTED BELOW ARE NOT WARRANTED BY FAIRMONT. SEE TERMS OF EQUIPMENT OR SUPPLYING MANUFACTURER'S WARRANTIES, IF ANY, COVERING THESE ITEMS AND READ THEIR WARRANTIES CAREFULLY: Furniture, furnishings, and drapes – Floor coverings and carpeting – Electric and gas appliances and fixtures – Furnace – Water heater – Smoke detector – Windows & doors – Wall and ceiling coverings –**
- **Plumbing and electrical fixtures and components – Ground fault interrupters – Finishes on wood or plastic or vinyl or metal – Air conditioner – Tires – Gas valves – Running gear.**
- **FAILURE WHICH MAY BE CAUSED BY, OR RELATED TO ABUSE, MISUSE, NEGLIGENCE, OR ACCIDENT; FAILURE WHICH MAY BE RELATED TO ALTERATION(S) OR MODIFICATION(S), FAILURE AS A RESULT OF NOT FOLLOWING INSTRUCTIONS CONTAINED IN THE FAIRMONT HOME OWNERS MANUAL, FAIRMONT INSTALLATION MANUAL, AND/OR ANY OTHER CARE AND MAINTENANCE MANUAL SUPPLIED WITH THE HOME.**

- **DETERIORATION DUE TO WEAR OR EXPOSURE, SUCH AS FADING OF FABRICS OR DRAPES, CARPET WEAR, EXTERIOR SURFACES, ETC.**
- **MAINTENANCE ITEMS, INCLUDING, BUT NOT LIMITED TO, LIGHT BULBS, FUSES, AND MINOR ADJUSTMENTS.**
- **ANY CONSEQUENTIAL OR INCIDENTAL EXPENSES SUCH AS, BUT NOT LIMITED TO, LOSS OF TIME, COMMERCIAL LOSS, LOSS OF USE, LODGING, FOOD, TELEPHONE CALLS, TRAVEL, INCONVENIENCE, RENTAL CHARGES OR STORAGE FEES. FAIRMONT WILL NOT BE LIABLE FOR ANY DAMAGES WHATSOEVER ARISING OUT OF THE USE OR INABILITY TO USE A HOME, EVEN IF FAIRMONT HAS BEEN ADVISED OF THE POSSIBILITY OF SUCH DAMAGES. TO THE MAXIMUM EXTENT PERMITTED BY APPLICABLE LAW, FAIRMONT DISCLAIMS ANY RESPONSIBILITY FOR INCIDENTAL OR CONSEQUENTIAL DAMAGES.**
- **LOSS OR DAMAGE CAUSED BY INSURRECTION, RIOT, OR ACT OF THE PUBLIC ENEMY, LOSS OR DAMAGE CAUSED BY FORCES OF NATURE, INCLUDING BUT NOT LIMITED TO FLOOD, WIND, STORM, HURRICANE, TORNADO, BLIZZARD, EXPLOSION, OR FIRE.**
- **ANY OTHER ITEM NOT OTHERWISE PREVIOUSLY REFERENCED IN THIS SECTION 5 AND WHICH IS NOT SPECIFICALLY REFERENCED AS A WARRANTED ITEM IN SECTION 1 OF THIS LIMITED WARRANTY.**

## **6. IMPORTANT FACTS**

Fairmont does not warranty against "defects" or "shortages" readily apparent on delivery unless noted on delivery documents of the transportation driver. Please inspect your Home and make sure you accept it as delivered to you. This Home has been sold to an authorized Retailer, and not an agent of Fairmont, for resale in the ordinary course of the Retailer's business, on terms and conditions and equipped as the Retailer and you determine, and your agreement is solely with the Retailer, not Fairmont. Fairmont does not participate in retail sales or retail contracts, other than by terms of this Limited Warranty. Fairmont does not control or do set-up, alignment, foundation, pier, or pad or any other site work or preparation.

Fairmont reserves the unrestricted right at any time and from time to time to make changes in the design of and/or improvements upon its homes without thereby imposing any obligations upon itself to make corresponding changes or improvements in or upon its homes already manufactured. Fairmont further reserves the right to substitute parts or components of substantially equal quality in any warranty service required by operation of this Limited Warranty. Like any other product, a Home and the products installed in it will require care and maintenance attention by the Purchaser and occupants. Please read carefully and follow all care and maintenance manuals, warning labels, safety notices and instructions supplied with the Home.

Because innumerable local restrictions and building codes exist, Fairmont does not warrant that its homes meet a particular code or zoning code other than as affixed seals indicate at the time and place of manufacture. Manufactured homes are built according to the National Manufactured Housing Construction and Safety Standards Act of 1974, as amended, and as regulated and amended by the United States Department of Housing and Urban Development that were current at the time of manufacture ("HUD Code"). Modular homes are built in accordance with the International Residential Code (IRC) and any applicable state modular code.

Fairmont uses where it deems feasible, UL or other certifying agencies approved products such as wiring and electrical fixtures and plumbing components – but as an assembler of such products, Fairmont does not undertake or insure or guarantee their effectiveness – or warrant against hidden defects or failures or damage to person or property caused by such failures at any time.

## **7. JURISDICTION AND APPLICABLE LAW**

Exclusive jurisdiction for deciding claims, demands or causes of action for defects or representations of any nature or damages due from such defects or representations shall be in the courts of the State of manufacture. The laws applicable to any litigation, dispute, mediation, arbitration or any claim whatsoever arising from the sale, purchase, or use of the Home shall be those of the State of Manufacture. The State of Manufacture of the home is Indiana.

This Limited Warranty gives the Purchaser specific legal rights and the Purchaser may have other rights that may vary from state to state. Fairmont is not responsible for any representation or warranty that is not herein stated unless required by applicable state or federal law. Some states may prohibit certain exclusions from express warranty coverage, and/or the exclusion of remedies and implied warranties. Some states do not allow limitations on how long the purchaser's remedies are available or an implied warranty lasts, so, to the extent applicable state law permits a remedy or an implied warranty obligation on the part of Fairmont, the limitation of remedies stated in Section 1 may not apply. Some states do not allow the exclusion of limitation of damages, so, to the extent applicable state law does not permit such limitation or exclusion, the limitation and exclusions set forth in Section 2 may not apply. Consult your personal attorney to determine all rights under the state and federal consumer laws which may offer remedies in addition to or different from this warranty.

Notwithstanding anything herein to the contrary, if the Purchaser is a resident of the State of Wisconsin, the following provisions apply to Wisconsin Purchasers:

1. This Home meets those standards prescribed by law or the Wisconsin Administrative Rules that are in effect at the time of the manufacture of the Home.
2. The provisions in this Limited Warranty regarding jurisdiction and applicable law do not apply.
3. If a repair, replacement, substitution or alteration is made under this Limited Warranty and it is discovered, before or after expiration of the warranty period, that the repair, replacement, substitution, or alteration has not restored the home to the condition in which it was warranted except for reasonable wear and tear, then notice of this shall be provided to Fairmont in the manner prescribed herein. Fairmont will then restore the Home to the condition in which it was warranted to be at the time of the sale except for reasonable wear and tear, at no cost to the Purchaser or the Purchaser's assignee notwithstanding that the additional repair may occur after the expiration of the warranty period.
4. If during any period of time after notification of a defect the Home is uninhabitable, as defined by the Wisconsin Administrative Rules, that period of time shall not be considered part of the one year period.

**I/WE HEREBY ACKNOWLEDGE THAT I/WE HAVE READ AND RECEIVED THIS LIMITED WARRANTY PRIOR TO ENTERING INTO ANY CONTRACT TO PURCHASE MY/OUR FAIRMONT HOME AND AGREE TO ABIDE BY ALL OF ITS TERMS AND PROVISIONS INCLUDING, BUT NOT LIMITED TO, THE DISCLAIMER OF ALL OTHER EXPRESS AND IMPLIED WARRANTIES, INCLUDING ANY IMPLIED WARRANTY OF MERCHANTABILITY OR FITNESS FOR A PARTICULAR PURPOSE, TO THE EXTENT APPLICABLE LAW ALLOWS, AND THE PROVISIONS HEREOF PROVIDING THAT THE EXCLUSIVE JURISDICTION FOR ANY CLAIMS WHATSOEVER SHALL BE IN THE COURTS IN THE STATE OF MANUFACTURE AND THAT THE APPLICABLE LAW SHALL BE THE LAW OF THE STATE OF MANUFACTURE.**

SIGN \_\_\_\_\_  
(INITIAL RETAIL PURCHASER)

DATE \_\_\_\_\_

SIGN \_\_\_\_\_  
(INITIAL RETAIL PURCHASER)

DATE \_\_\_\_\_

### **3-2 HUD DISPUTE RESOLUTION PROGRAM**

#### **Dispute Resolution Process/Dispute Resolution Information**

Many states have a consumer assistance or dispute resolution program that homeowners may use to resolve problems with manufacturers, retailers, or installers concerning defects in their manufactured homes that render part of the home unfit for its intended use. Such state programs may include a process to resolve a dispute among a manufacturer, a retailer, and an installer about who will correct the defect. In states where there is not a dispute resolution program that meets the federal requirements, the HUD



Manufactured Home Dispute Resolution Program will operate. These are “HUD-administered states.” The HUD Manufactured Home Dispute Resolution Program is not for cosmetic or minor problems in the home. You may contact the HUD Manufactured Housing Program Office at (202) 708-6423 or (800) 927-2891, or visit the HUD website at [www.hud.gov](http://www.hud.gov) to determine whether your state has a state program or whether you should use the HUD Manufactured Home Dispute Resolution Program. Contact information for state programs is also available on the HUD website. If your state has a state program, please contact the state for information about the program, how it operates, and what steps to take to request dispute resolution. When there is no state dispute resolution program, a homeowner may use the HUD Manufactured Home Dispute Resolution Program to resolve disputes among the manufacturer, retailer, and installer about responsibility for the correction or repair of defects in the manufactured home that were reported during the 1-year period starting on the date of installation. Even after the 1-year period, manufacturers have the continuing responsibility to review certain problems that affect the intended use of the manufactured home or its parts, but for which correction may no longer be required under federal law.

### **Dispute Resolution Process/Dispute Resolution Information**

The steps and information outlined below apply only to the HUD Manufactured Home Dispute Resolution Program that operates in HUD-administered states, as described under the heading “Dispute Resolution Information” in this manual. Under the HUD Manufactured Home Dispute Resolution Program, homeowners must report defects to the manufacturer, retailer, installer, a State Administrative Agency, or HUD within 1 year after the date of the first installation. Homeowners are encouraged to report defects in writing, including, but not limited to, email, written letter, certified mail, or fax, but they may also make a report by telephone. To demonstrate that the report was made within 1 year after the date of installation, homeowners should report defects in a manner that will create a dated record of the report: for example, by certified mail, by fax, or by email. When making a report by telephone, homeowners are encouraged to make a note of the phone call, including names of conversants, date, and time. No particular format is required to submit a report of an alleged defect, but any such report should at a minimum include a description of the alleged defect, the name of the homeowner, and the address of the home.

Homeowners are encouraged to send reports of an alleged defect first to the manufacturer, retailer, or installer of the manufactured home, or a State Administrative Agency. Reports of alleged defects may also be sent to HUD at: HUD, Office of Regulatory Affairs and Manufactured Housing, Attn: Dispute Resolution, 451 Seventh Street, SW., Washington, DC 20410-8000; faxed to (202) 708-4213; emailed to [mhs@hud.gov](mailto:mhs@hud.gov), or reported telephonically at (202) 708-6423 or (800) 927-2891.

If, after taking the steps outlined above, the homeowner does not receive a satisfactory response from the manufacturer, retailer, or installer, the homeowner may file a dispute resolution request with the dispute resolution provider in writing, or by making a request by phone. No particular format is required to make a request for dispute resolution, but the request should generally include the following information:

1. The name, address, and contact information of the homeowner;
2. The name and contact information of the manufacturer, retailer, and installer of the manufactured home;
3. The date or dates the report of the alleged defect was made;
4. Identification of the entities or persons to whom each report of the alleged defect was made and the method that was used to make the report;
5. The date of installation of the manufactured home affected by the alleged defect; and
6. A description of the alleged defect.

Information about the dispute resolution provider and how to make a request for dispute resolution is available at <http://www.hud.gov> or by contacting the Office of Manufactured Housing Programs at (202) 708-6423 or (800) 927-2891.

A screening agent will review the request and, as appropriate, forward the request to the manufacturer, retailer, installer, and mediator. The mediator will mediate the dispute and attempt to facilitate a settlement.

The parties to a settlement include, as applicable, the manufacturer, retailer, and installer. If the parties are unable to reach a settlement that results in correction or repair of the alleged defect, any party or the homeowner may request nonbinding arbitration. Should any party refuse to participate, the arbitration shall proceed without that party's input. Once the arbitrator makes a non-binding recommendation, the arbitrator will forward it to the parties and HUD. HUD will have the option of adopting, modifying, or rejecting the recommendation when issuing an order requiring the responsible party or parties to make any corrections or repairs in the home. At any time before HUD issues a final order, the parties may submit an offer of settlement to HUD that may, at HUD's discretion, be incorporated into the order.

In circumstances where the parties agree that one or more of them, and not the homeowner, is responsible for the alleged defect, the parties will have the opportunity to resolve the dispute outside of the HUD Mediation and Arbitration process by using the Alternative Process. Homeowners will maintain the right to be informed in writing of the outcome when the Alternative Process is used, within 5 days of the outcome. At any time after 30 days of the Alternative Process notification, any participant or the homeowner may invoke the HUD Manufactured Home Dispute Resolution Program and proceed to mediation.

The HUD Manufactured Home Dispute Resolution Program is not a warranty program and does not replace the manufacturer's or any other warranty program.

## **EXTERIOR MAINTENANCE**

**NOTE:** A wise homeowner will perform the small tasks of preventative maintenance that are his responsibility and thus avoid major repair costs in the future due to ignoring owner maintenance requirements.

### **4-1 ROOF**

The roof of your home has been covered with either painted steel, residential type shingles, or a rubber roof membrane, which are applied over an approved underlayment. You should make periodic inspections of your roof, especially in the fall and early spring, to ensure the early detection of a lost weather seal or other undesirable condition.

In the winter, snow and ice may accumulate on the roof and sometimes a condition is produced where the ice and snow curve over the roof edges or eaves. This condition can, in some cases, contribute to roof leaks in both metal and shingle roofs. Ice expanding at the roof edge can cause leakage problems that normally would not occur in areas where ice and snow build-up are not a problem. You are advised to keep the build-up at the eaves to a minimum so as to avoid any problems. Tools or devices designed for this task are available through your local hardware retailer as are ice melting products which leave no residue to stain shingles or siding, and are designed to remove ice dams once they have formed.

Depending on your home site location, normal and extraordinary winter conditions can cause the amount of snow or ice buildup on your roof to accumulate beyond prudent levels. To avoid your home being damaged, you should have the snow and ice removed without delay. When you are leaving your home vacant, it is recommended that you arrange to have your roof cleared of any potentially damaging accumulations.

The annual realignment of your home on an owner's maintenance basis is essential to proper roof care. Settling can put excessive strain on the roof and cause buckling or seam separation, and interfere with window and door operation.

When inspecting the roof covering of your home, you should check for lost weather seals (cracks in the sealant material) around plumbing vents, flue pipes, roof ventilators, skylights, etc. Any lost weather seal you find or suspect must be treated at once to prevent damage to your home.

### **4-2 METAL ROOF AND RUBBER ROOF**

Walking on a metal or rubber roof should be avoided. Most roof inspections, cleaning, and repair work can be accomplished from a ladder. You should walk on the roof of your home only when it becomes absolutely necessary. When walking or working on the roof, use extreme caution to avoid personal injury and damage to the roof material.

### **4-3 SHINGLED ROOF**

The condition of the roof covering must also be inspected to insure that roof shingles and ridge cap shingles are firmly in place. The seal tabs on the shingles require several days of continued high temperatures to seal. If, during your inspection, you find that a shingle tab has not sealed to the shingle below it, a seal may be accomplished by placing a small amount of asphalt plastic cement between upper and lower shingles. Exposed surface nailing should be avoided when possible and treated with asphalt plastic cement when not possible.

If you have installed gutters on your roof edge, they should have tight joints and be kept free of accumulated leaves and dirt. Any seams in the gutter material should be sealed where necessary. Gutters should be inspected more frequently in wooded areas.

The shingle manufacturer's limited warranty on the shingles does not cover damage done by winds in excess of 60 miles per hour which are considered acts of God, not as normal wear. Please note that isolated thunderstorms and weather fronts create wind forces through 60 miles per hour, often with rotation and/or shear characteristics. While they may be of momentary existence and very limited in the area of the roof the affect, they can rip shingles off of a home and such an occurrence requires that the missing shingles or broken tabs be replaced immediately to avoid water damage from future storms. Most homes will experience such conditions at one time or another in their life and should be maintained by the home owner.

#### **4-4 EXTERIOR FINISHES AND THEIR CARE**

The exterior siding of your home is either a pre-finished metal, vinyl, or a wood fiber product. Each type of siding has certain advantages and disadvantages. The advantages of metal and vinyl over wood fiber products are that the finish on vinyl and metal is more durable than the finish on wood fiber. Vinyl and metal are not subject to humidity absorption over the years. Vinyl and metal are less likely to have the swelling and distortion because of the expansion pressures over the years, and they do not require sealing and painting periodically to avoid these conditions. Wood fibers, because of their ability to absorb moisture, must be resealed from time to time. In this regard, we recommended no less than every three (3) years or earlier if required. Metal siding and vinyl siding are more resistant to impact damage causing dents unless they are exposed to severe impacts. Both metal siding and vinyl siding are subject to normal expansion during the heat of a hot summer and will expand in the day and contract on cool evenings, especially when they are not in the shade. This will cause some noticeable undulation in the surface of the siding, but it does not affect its structure. Vinyl siding, although having this slight rippled effect in extremely hot weather, has some unique advantages in that it is impervious to water. It does not absorb moisture. It does not chip, peel, rust, or oxidize, and its color runs completely through the material so that scratches are minimal and less apparent. In addition, vinyl siding does not fade as much as metal or wood fiber sidings when exposed to sunlight over a period of time, eliminating the noticeable difference in color when replacing a damaged section of siding. Replacement metal or wood will be off-shade, as will vinyl to a lesser extent. Dirt left to accumulate will etch or stain siding and support mold growth. Proper cleaning and protecting will prolong the life of these materials.

Metal and vinyl can be cleaned with a mild detergent and a sponge or soft brush. The siding should be thoroughly rinsed after cleaning. Abrasive cleaners should not be used on metal or vinyl siding. Small puncture holes in this siding can easily be made weather resistant by applying a high grade silicone sealant to the affected area.

As is the case with any home sided with wood fiber products; periodic re-staining or repainting is required. Information on treatment of wood product siding can be obtained from your local hardware or paint store. As always, it is important to keep the siding material sealed against the elements.

#### **4-5 WINDOWS AND DOORS**

All joints around windows and door casings were thoroughly caulked at the factory. Road shock and vibrations may have compromised these weather seals.

**CAUTION:** Any leak around the doors and windows should be corrected immediately. If the water reaches the floor and is allowed to stand, the floor will swell and deteriorate, causing it to fail and could result in serious injury.

The doors and windows in your home were fully operational at the time of manufacture of your home. If doors or windows stick or seem misaligned, it is likely that your home is not in proper alignment. The realigning of your home will correct this problem.

#### **4-6 PROPER ALIGNMENT**

A manufactured home is cambered and reverse cambered along the I-beam as part of the engineering for the stress of transportation. Likewise it is cambered from side to side for transportation stresses and live load as well as dead load stresses. Consequently, siding, flooring, and roof lines will have variations due to camber lines, which are normal. The home should be blocked and shimmed on the foundation to follow natural camber and reverse camber lines as the home is received from the factory.

A properly maintained installation will, under normal conditions, protect the home from the effects of frost heave and settling and avoids the possibility of incurring expensive repair bills. If your home is not set and maintained in proper alignment as it was designed, or if it is not set on a completely firm and proper foundation system as described in the installation manual, certain portions of your home will undergo undue and unnatural structural

strain. Such structural strain could lead to problems later. Typically, these problems appear in the form of the buckling, loosening, or separating of wall coverings, exterior siding, floors and their coverings, ceilings, metal roof membranes and miscellaneous fixed original fixtures and cabinets of the home. Other problems relating to installation include the leaking of doors, windows, roofs, ceilings, and exterior walls due to the loss of the weather seals in these areas, as well as the loss of proper operation of windows and doors and their locking devices. The alignment and supporting piers must be checked on an annual basis as part of your owner's maintenance program. An installation manual was provided with your home at the time of manufacture and should have been passed to you by your retailer. If you did not receive a copy, contact your retailer and ask for your copy. **PLEASE READ THIS MANUAL.**

#### **4-7 BOTTOM BOARD CLOSURE**

The underside of your manufactured home is covered with a closure material commonly called bottom board. This material may be a laminated plastic product, or a woven plastic product. This material encloses and protects the in-floor plumbing, electrical, mechanical, and thermal systems.

Should the bottom board become damaged by tearing or cutting during the installation of your home or at any other time, it can be repaired by using a patch of like or equal material held in place with a high-tack spray adhesive.

To repair a hole or tear in the bottom board, cut a piece of bottom board material that is four (4) inches larger than the widest point of the hole or tear. To repair or to tighten the fit around a pipe penetration in the bottom board cut a piece of bottom board approximately six (6) inches wider than the pipe in all directions. Cut the hole for the pipe so that it will fit exactly. The patch may be slit for the center hole to the edge to allow the patch to slip around the pipe. Spray both the patch and the area to be repaired with a spray adhesive such as "STA-PUT" or an equivalent. Let the spray air for one (1) to three (3) minutes and install the patch over the hole. Smooth the patch firmly into place to insure full contact.

Make certain you read and understand the cautions, warnings, health notices, and directives found on the spray adhesive label before using. Always follow the adhesive manufacturer's directions for use, storage, and disposal.

#### **4-8 PORCHES AND DECKS**

Wooden porches and decks need to be inspected on an annual basis to ensure that the framing members and surface boards are sound and tightly secured in place. Any unsound material or loose connections should be corrected without delay.

Following the inspection and maintenance of the porch or deck, the framing members and surface boards should be treated with a high quality wood preserver/sealant to protect the material from exposure to moisture. Even pressure treated materials will need to be protected.

Handrails and guardrails which may have been added to the porch or deck due to the elevations above grade at the home site in accordance with the requirements of the local jurisdiction must also be inspected, maintained, and treated on an annual basis.

#### **4-9 STEEL FRAME ASSEMBLY**

The steel frame assembly under your home has a corrosion resistant coating. An annual inspection should be made to ensure that the resistance has not been compromised by road salts or moisture. Corroded areas should be cleaned and painted with a rust inhibiting paint.

#### **4-10 GROUND MOISTURE CONTROL**

When the space beneath the home is enclosed with skirting or other materials, a minimum 6 mil thick polyethylene sheeting vapor retarder must be installed to cover the ground under the home, unless the home is installed in an arid region with dry soil.

The entire area beneath the home must have been covered with the vapor retarder except for areas under open porches, decks, and recessed entries. The vapor retarder may have been placed directly beneath the partings, or otherwise installed around or over footings placed at grade, and around anchors or other obstructions. Joints in the vapor retarder need to be overlapped at least 12 inches. The lap should be oriented so that the sheet with the higher elevation overlaps the sheet with the lower elevation to promote the runoff of water from any source.

Tears and voids in the vapor retarder must be repaired using a 2 inch (min.) wide contractors sheathing tape suitable for use with polyethylene sheeting. The tape must be installed on a surface that is dry and free from oil and other contamination and within its manufacturer's temperature limitations. To repair a tear, cut a piece of tape approximately 4 inches longer than a tear, center it over the tear with an approximate 2 inch extension on each end and press it firmly in place on the vapor retarder. Depending on the length and nature of the tear multiple overlapping layers may be needed. To repair a void, cut a piece of polyethylene sheeting large enough to extend at least 12 inches beyond the edges of the void and tape it in place along its edges as though it was a tear.

#### **4-11 ATTACHMENTS**

Should you elect to fasten an item to the outside of your home, you are advised to use extreme caution when doing so to avoid damaging the home or injuring yourself, family members or guests.

## **INTERIOR MAINTENANCE**

**NOTE:** The interior of your home needs no more than the regular common sense attention required to keep any home in good condition. In fact, because of the many modern, durable, components employed in its construction, your home's maintenance should be easier than most. Some special maintenance tips follow:

#### **5-1 WALLS**

Pre-finished paneling - various products are sold in hardware and lumber stores to maintain paneling. These include lemon oil, furniture polish, panel cleaners, etc. Do not use solvents.

Vinyl wall coverings - Walls should be washed with a light detergent once a year. However, if smokers reside in the home or the preparation of fried foods is common, the walls should be washed twice a year to prevent permanent discoloration of the walls, trim and fillers. For removing heavy grime or dirt, products such as Formula 409 all-purpose cleaner, Greased Lightning all-purpose cleaner, and Mr. Clean Magic Erasers may prove effective; rinse clean with clear water. Abrasive cleaners and solvents should never be used.

#### **5-2 CABINETS**

Vinyl covered doors - same as vinyl walls.

Wood - treat like a fine piece of furniture.

Cabinet hardware - These are lacquer finished to preserve original luster. Wipe with a damp cloth.

Cabinet drawers - If any drawers should stick, apply beeswax or a bar of soap to drawer guides to make them slide easier.

#### **5-3 TUB AND LAVATORIES**

Use a mild detergent. Do not use any type of abrasive cleanser. Abrasive cleansers will scratch molded fiberglass and plastic tubs, showers, and lavatories.

#### **5-4 FURNITURE**

Upholstered furniture should be professionally cleaned. Use a good quality furniture polish on wood furniture.

#### **5-5 COUNTER TOPS**

Use a mild detergent to clean counter tops. Do not use abrasive cleansers or solvents. Use a cutting board to protect counter when preparing food. Do not allow water to stand near or behind the sink where it may enter and damage the counter substratum. Always use a hot pad or trivet with rubber feet to protect counter top from hot surfaces.

#### **5-6 DRAPES AND SPREADS**

These should be professionally dry cleaned. **DO NOT WASH DRAPES OR SPREADS.**

## 5-7 LOOSE MOULDING

Popped moulding caused in transit or by settling can be rectified by use of an ordinary finishing nail.

## 5-8 FLOORS

Carpet - All carpet should be vacuumed and cleaned regularly and kept clean for long wear. A professional steam cleaning once a year would be the best way to insure long carpet life.

Linoleum - Linoleum will look better and last longer if it is cleaned and waxed regularly. Avoid excessive application of water as it may cause lifting and curling.

Excessive Moisture - Water should not be allowed to stand on linoleum or carpet covered floors. Damp areas on the carpet should be dried to prevent the growth of mold or mildew. Areas which are continually damp or wet should be investigated to find and correct the cause. Water may be picked up with a mop or wet vacuum as needed and damp areas may be dried by one or more fans or dehumidifier.

## 5-9 CEILINGS

Mars and Gouges - Ceiling marks can be cleaned with a non-abrasive cleaner then wiped with a clean, soft, cloth. A scratch can be treated with a non-shrinking, color coordinated spackling paste. Deep scratches may require more than one application.

Dirt Smudges - Soft art gum erasers will probably remove dirt and fingerprints. If a portion of the smudge remains after the eraser has been used, the area should be wiped with a soft white chalk.

Water Stains - In some instances water stains can be taken out by bleaching them with Clorox. In other instances, repainting may be necessary.

Sprayed Textured Ceilings may be lightly dusted but not washed. Washing will remove the texture.

When ordinary redecoration becomes necessary, apply regular oil or latex wall paint. These may be applied by spraying or rolling. When rolling, keep your roller full of paint and use gentle strokes. Do not use a scrubbing action.

If your ceiling should become stained, do the following: Try to take the stain out by bleaching. If this fails, the stained areas will need to be sealed and the ceiling painted.

## 5-10 WATER CLOSETS

The bowl and water tank are generally made of vitreous china and can be cleaned with any of the products sold for that purpose. However, should the water tank be made of a plastic material, a mild detergent should be used rather than an abrasive cleaner.

The water tank connection to the bowl rests on the gasketed water passage between the tank and the bowl. Since this is not a completely rigid connection, a certain amount of flexibility is to be expected. Leaning back against the tank, however, could result in a water leak or actual damage to the tank.

If you detect a water leak at the tank to bowl connection, and have confirmed that the water source is not from condensation, the tank to bowl bolt connection should be carefully tightened.

**CAUTION:** Over tightening could damage the tank or bowl. If the leak continues, replace the gasket between the tank and bowl.

If you detect a water leak at the base of the bowl and have confirmed that the source of the water is not a leak at the water tank or condensation, the wax ring under the bowl at the sewer connection should be changed. Continued exposure to water will damage your floor and its covering.

The operation of the ball cock, flapper valve, and flush valve may all be adjusted inside the water tank to suit your needs or water pressure.

## 5-11 WHIRLPOOL BATH TUBS

At the time of the first use of a whirlpool bath tub, where installed, remove the access panel for the circulation pump to make certain that the water tube connections at the pump have not loosened. Tighten where needed.

## 5-12 CONDENSATION

Warm air has the ability to hold much more water vapor than cold air, and water vapor has a tendency to move from a warmer to a cooler place. The combination of the above facts leads to a condition that can occur in all modern, well-constructed homes. This condition is known as condensation.

Condensation and its winter counter-part, frost, forms when warm moisture laden air contacts a cooler surface. The only way to control condensation is to control humidity, the amount of moisture in the air. It is important to understand that humidity, condensation, and frost are not built into a home, but originate from such necessary living requirements as cooking, laundering, bathing, dishwashing, house cleaning, plants, aquariums, etc., as well as from the breathing and perspiring of people. In a typical family of four, the average daily product of water vapor from these sources may be as much as 25 pounds and may be much greater where appliances such as automatic washers and dryers are used. Other large sources of water vapor are the bare earth underneath the home and the use of kerosene heaters. The burning of one gallon of fuel in a kerosene heater releases over 9 pounds of water into the home as a by-product of combustion. All of this water vapor must escape the home through natural ventilation such as a partly opened window or door, forced ventilation such as a kitchen or bathroom exhaust fan, or the use of one or more dehumidifiers. Unchecked water vapor build-up can damage your home and affect your personal well-being.

The accompanying chart prescribes recommended humidity levels for present outside temperatures. A hygrometer measures humidity and may be purchased at any drugstore. This instrument may be used to monitor the humidity level in your home.

The following practices should be followed in order to reduce humidity and consequent condensation:

1. Use storm windows.
2. Turn on exhaust fan in kitchen when using range.
3. Keep registers and furnace filters clean to insure good air circulation.
4. Do not dry laundry in your home unless you use a mechanical dryer, which is vented to the outside. Dryer must be vented to the exterior of the home. Never let a vent empty below your home. This will cause an accumulation of moist air below your home and the lint build-up will create a fire hazard.
5. When using the shower or bathtub, and for thirty minutes thereafter, it is recommended that the door be closed and the vent fan be left running so as to keep the buildup of moisture from spreading through your home.
6. Beds and furniture should be spaced away from walls to permit free air circulation. Free air circulation discourages mold and mildew growth.
7. Make certain the skirting or crawl space is properly ventilated. Improperly installed skirting will cause moisture to accumulate beneath the home. The skirting must not be attached in a manner that can cause water to be trapped between the siding and trim or forced up into the wall cavities trim to which it is attached. The area beneath the home must be ventilated. The minimum vent area shall be one square foot of net free area (area of opening in grillwork) forever 1,500 square feet of area under the home. (Length of home multiplied by width of home divided by 1,500 equals net free area of vent required in square feet.) Install an equal number of ventilators along each side of the home. One ventilator should be within three feet of each end of the home with the remainder equally spaced along the length of the home and located across from one another. This will allow for cross-ventilation and dissipate damaging condensation. In addition to the ventilation, a six-mil visqueen vapor barrier must have been installed under your home as described in your installation manual. In like manner, a home installed on permanent foundations must also have the foundation properly vented.
8. Rooms should be frequently aired out, preferably once a day.
9. Some seepage of air through the windows is desirable. Outside air is dryer than inside air and helps to maintain lower humidity. Do not tape doors or windows closed to prevent any movement of air.
10. Kerosene heaters should not be used without a positive venting system for the combustion gases.
11. A small, inexpensive dehumidifier may be purchased if humidity cannot be lowered by the above precautions.

The only way to control condensation is to control humidity. If a homeowner insists on maintaining relative humidity ranging above 40 percent and will not attempt to control moisture in his home, then he will have to accept condensation and other problems caused by water vapor. Now, before we summarize specific steps for reducing relative humidity (R.H.) in your home, let's include some basic data about recommended moisture.

<u>Outside Air Temperature</u>	<u>Inside R.H. for 70°F Indoor Temperature</u>
-20°F or less	not over 15%
-20°F to -10°F	not over 20%
-10°F to 0°	not over 25%
0°F to 10°	not over 30%
10°F to 20°	not over 35%
20°F to 40°	not over 40%

### **5-13 TO SUMMARIZE**

1. Install storm windows.
2. Recognize that the only way to stop condensation is to reduce moisture in your home.
3. Be willing to try living in lower humidity.
4. Turn off any source of moisture which you can control.
5. In the winter, provide more controlled ways for inside air to get out and for dry, outside air to get in.

If troublesome condensation still persists, purchase one or more dehumidifying devices and operate as needed. Condensation is a natural occurrence which is brought on by excessive moisture (humidity) in the air within the home. The conditions which may create excessive humidity must be controlled by you, the homeowner. Condensation and damages associated with it are not warranty service problems.

### **5-14 WINTER PRECAUTIONS**

In the event you elect to vacate your home during the winter months, care should be taken to ensure that adverse weather conditions will not damage your home.

Follow the procedures listed in the Utility Systems section of your installation manual to properly drain your water system and add antifreeze to your P-traps at all locations.

The heat should be left on to maintain a temperature that will not allow the build-up of moisture and the growth of mold. Moisture build-up can cause swelling or warping of materials and furnishings.

Provisions should also be made to inspect the home on a weekly basis to ensure that the skirting ventilators are open and not snow-covered. Also to remove any ice and snow build-up along the eaves, as stated earlier in this manual, and to prevent the water created by melting ice and snow from backing up under the shingles or entering the home by other means.

### **5-15 INTERIOR VENTILATION.**

In addition to the opening of doors and windows to provide fresh air to the interior of your home, a whole house ventilation system has been installed to provide ventilation in keeping with building code requirements. The introduction of fresh air will aid in the elimination of stale air and odors while reducing the overall relative humidity.

The whole house ventilation system installed in your home is designed to function during the normal operation of your furnace and air conditioning system. This system allows outside air to be mixed with the air inside your home as the furnace is running. This operation keeps your inside air from becoming stale.

Since the ventilation system is dependent on the operation of your heating and cooling system, it is important that during those times of the year, when your furnace or air conditioner are not running, you continue to operate the whole house ventilation system when the house is occupied. This can be done by adjusting the thermostat controls from "AUTO" to "FAN" or "VENT" depending on the type of thermostat that has been installed in your home.



## **5-16 MOISTURE AND YOUR HOME ENVIRONMENT**

As you are probably aware, unwanted moisture or water can get into your home through accidental or natural causes such as storm damage to roof shingles, roof vents, or siding; or the aging of the weather seals in various areas such as roof, windows, doors, siding, etc. It is extremely important that all seals be inspected and maintained on an annual basis in accordance with your homeowner's manual to prevent the introduction of undesired moisture into your home. At the first indication of moisture penetration take immediate steps to stop the source of moisture into your home. If your home is under warranty and the problem is due to a manufacturing or retailer installation, request service immediately. Serious damage to your home and its environment can occur with deterioration of materials and the growth of bacteria or mold.

Microbial such as mold or bacterial, exist everywhere in outdoor and indoor environments in various concentrations. If allowed to settle in a warm, moist area undisturbed, they can continue to multiply and there is a possibility of allergic reactions. For this reason, any building materials that have become excessively moist should be dehumidified and carefully inspected. Once materials have been returned to their normal humidity level, we recommend treatment with an anti-microbial solution recommended by the solutions manufacturer to kill microbial such as mold and bacteria. Structural materials should be coated with borax solution (1 pound borax to 1.5 gallons of water) or with Kilz.

## **HOME SAFETY FEATURES**

### **6-1 EGRESS WINDOWS**

All manufactured homes built under the federal standard are required to have an emergency exit window in each bedroom which does not have an exterior door. This window, called an egress window, must have an instructional label on it when the home is delivered to the homeowner. We suggest you leave these instructions attached. All members of the family should be taught how to operate the window and to test it occasionally to see that it is in working condition. Access to the egress window should never be blocked.

### **6-2 SMOKE ALARM**

All manufactured homes are equipped with smoke alarms positioned to protect each bedroom, the living/kitchen area, and the basement (for homes having a factory installed basement access). The home's electrical system is the primary power source to provide continued protection in the event of a power failure in your neighborhood. These devices are sensitive to smoke in the initial stages of a fire and will sound an internal horn to alert occupants during a fire.

Most alarms incorporate a small light to indicate that the alarm is functioning properly, another light or audible sound to indicate the status of the battery, and a silencing mechanism to temporarily mute the horn when the alarm has been activated by smoke from cooking.

It is essential that the smoke alarms be tested at the time the home is installed at the home site. Testing smoke alarm is a simple operation, but may require the use of a stepladder to safely reach each one and some one to help in determining if they all sound their horns at the same time.

Begin by locating each smoke alarm and using the following procedure. Where the smoke alarm manufacturer has different printed instructions, follow those instructions:

1. Check to see that the green light is on, indicating AC power is connected to the alarm. If the green light is not on, check that the unit is properly wired and the circuit breaker is on.
2. Check that the red LED flashes approximately once a minute. If not, replace the battery (where the smoke alarm has a permanent battery, the smoke alarm will need to be replaced).
3. Depress and hold the test button for 3 seconds. A loud pulsating alarm should sound.
4. Test each alarm separately in the system.
5. Determine that the initiating alarm triggers other alarms in the system. It may be necessary to have help from another family member to listen in other parts of the home.
6. Should a smoke alarm not sound, confirm that it is properly connected to the branch circuit and that the circuit has power. If it still fails to sound, it must be replaced and its replacement tested.

For additional protection you may install additional battery powered smoke alarms, for those areas where additional protection is desired, and establish an exit plan for your home. The battery must be replaced as often as needed, as indicated by testing, or once each year, whichever ever comes first. Always replace alarms immediately if they are not working properly. Please read the manufacturers operating instructions.

We recommend that you replace smoke alarms every ten years, even though you have tested them in accordance with the manufacturer's recommendations or at least once per year and they appear to be operating correctly.

### **6-3 GFCI CIRCUIT BREAKER**

All exterior, kitchen (within 6 feet of the sink and servicing counter top spaces), and bathroom receptacles of the manufactured home must be guarded by a ground fault circuit interrupter (GFCI). This GFCI is a safety device installed to protect the occupant from electrical shock. If the GFCI has tripped to the "OFF" position due to a fault in the circuit, the receptacle, which it services, will not operate. The reset button on the GFCI will reactivate it. You should periodically check the operation of each GFCI by pressing the "Test" button located on the GFCI receptacle in the rear bathroom or in the case of a GFCI circuit breaker, adjacent to the circuit breaker inside the electrical distribution panel. When the "Test" button is depressed, the circuit breaker should trip to indicate proper operation of the GFCI. You can then reset the breaker to restore electricity to the circuit.

### **6-4 FIRE PROTECTION**

Certain areas of your home are provided with extra fire protection. The furnace and water heater cavities are completely lined with non-combustible, fire-retarding panels. The area behind and above the range is also protected by non-combustible materials.

To reduce the risk of a range fire, the kitchen exhaust fan, usually located in the range hood, and filters must be kept free of grease build-up. Always turn the fan on when cooking and use the high heat setting on the range only when necessary. Whenever oil is to be heated, do so slowly using a low to medium setting. Always use cookware and utensils appropriate for the type and amount of food being prepared, and do not leave the range unattended when cooking. Kitchen towels should be kept clear of the range top at all times.

### **6-5 VENTED KITCHEN**

All kitchen areas are vented to the exterior by means of wall, ceiling, or range-hood exhaust fans. This provision permits exit of cooking fumes, smoke, and helps control condensation by removing moisture-laden air.

### **6-6 GROUND ANCHORS**

Your installation instructions indicate the recommended manner in which your home should be secured to the ground. These ground anchor recommendations should be followed so as to secure the home during periods of high winds. It should be advised that no manufactured home, anchored or otherwise, is safe during the extremely high wind conditions of a tornado or hurricane.

### **6-7 ELECTRICAL SYSTEM**

Your home is designed to be connected to an electrical supply source rated at 120/240 volts, 3-pole, 4-wire, 60-hertz having an insulated neutral. In making the feeder connections to this power source, it is extremely important that wires of the correct size, insulation type, and material be used. If wire is incorrectly sized, the ampacity for that wire may be exceeded resulting in a voltage drop within your home or an overheating of the wire which will cause the circuit breaker to trip protecting the wire from a short circuit (see figure 2).

It is vital for your protection that the home be properly grounded. The only safe and approved method of grounding your home is through the electrical isolated grounding bar located in the distribution panel which grounds all non-current carrying metal parts to the electrical system in your home to a single point. The ground conductor of the entrance feeder, in turn, connects the grounding bar to an electrical ground back through the feeder to the disconnect box (see figures 1 and 3). This means that for the 120/240-volt service, you must have a 3-pole, 4-wire feeder entrance.

**NOTE:** The manufactured home construction and safety standards and the national electrical code prohibit connecting the grounding bar and the neutral bar together in the distribution panel. The ground and the neutral are insulated from one another. It is extremely important that the grounding conductor and the neutral conductor from the distribution panel in the home be connected together at the disconnect box **located outside of the home (see figures 1 and 3). For this reason, all four of the service entrance feeder wires are absolutely essential.**

**WARNING!** If the grounding conductor and the neutral conductor are not connected together at the disconnect box and then properly grounded to the earth as required by the national electrical code, the individual branch circuit breakers located in the distribution panel within the home will not function and a short circuit at any time could cause an electrocution.

The complete grounding of your home is of utmost importance to your safety. You must make certain that the installer has fulfilled his responsibility of grounding your home. You are fully within your rights in demanding that he demonstrate that proper grounding has been accomplished. PLEASE refer to the service entrance connection drawing located at the distribution panel board in your home and figures 1 and 2 of this manual. Where the service entrance equipment has been installed on your home, please refer to figures 2, 3, 4, and 5 of this manual.

**NOTE:** It is essential that each frame section of a multiple section unit be bonded together using the bonding conductor and connectors provided on the home (see installation manual). Make certain that this connection has not been overlooked during the installation process. Without this connection a short circuit could energize the frame section.

Never tape, wedge, or otherwise lock a circuit breaker in the "ON" position so as to render it incapable of performing its function of guarding against circuit over loads and shocks. Contact between a red or black wire and ground should trip the circuit breaker. Guard against the overloading of circuits. Be especially careful of exterior outlets when using heating cables. Extension cords or multiple plugs should not be used with heating cables.

**CAUTION:** Only heat tapes listed for use in manufactured housing can be used. They must be listed for use with the type of material used in the protected system and must be installed in accordance with their installation instructions. Failure to follow these instructions could result in an electrical hazard or short circuit, which could cause a fire.

Your home's electrical system is equipped to handle all factory-installed equipment. Should additional major appliances be desired, check with your local utility or a qualified electrician. Additional branch circuits for electrical equipment added to the home in the after-market, such as air conditioning units, heat pumps and water pumps, as well as for ancillary structures such as porches, garages, work shops, barns, etc., must originate at a power source outside the home.

**NOTICE:** electrical connections made to energize air conditioning equipment should be made only by qualified personnel. The completed installation must conform to the requirements of the national electric code and applicable local standards.

**CAUTION:** the factory-installed clothes dryer electrical circuit is supplied by a cable containing 4 electrical conductors and terminates with a 4-prong receptacle. Do not change the 4-prong receptacle to a 3-prong receptacle. Purchase a 4-prong appliance cord and install it on your dryer.

**WARNING!** Do not install lamps (light bulbs) in the lighting fixtures that exceed the maximum wattage limit posted on or near the light fixture. Over lamping can cause an electrical shock or fire hazard.

For your safety and the safety of others who may have reason to be in or on your home, you must make certain that electrical lines or service conductors do not cross over your home or within easy reach of someone on your roof.

The exterior outlet(s) on your home are intended for attended use only and have been fitted with a weather resistant cover to protect them from the elements when not in use. Should inclement weather prevail, it is recommended that the use of the outlet be terminated until the weather clears. If the outlet must be used in all weather conditions, or when unattended, you must have the cover changed from a weather resistant cover to an approved and listed rain tight cover.

The electrical cord connecting appliances such as clothes dryers and clothes washers which may become mobile during operation should be inspected frequently to ensure that the cord has not become pinched and worn through by the movement and vibration of the appliance. This condition could cause an electrical short circuit initiating a fire or electrical shock.

## **6-8 FUEL SYSTEMS**

### **GAS**

All gas connections and hook-ups must be made by a qualified technician. Do-it-yourself gas connections are dangerous and are strongly discouraged by this company. Proper gas pressure should be maintained. Any wide variation from the normal level will adversely affect the pilot light stability of gas appliances. Either LP gas or natural gas may be used in your system, however, certain changes must be made when switching from one system to another. Before connecting the gas supply to the home, make certain that the correct size of orifice is installed in each appliance to handle the type of gas being used.

#### **IF YOU SMELL GAS:**

1. Extinguish any open flames, pilot lights, and all smoking materials.
2. Do not touch electrical switches.
3. Shut off the gas supply at the tank valve(s) or gas supply connections.
4. Open doors and other non-electrically operated ventilating openings.
5. Leave the area until the odor clears.
6. Call your fuel gas supplier and arrange to have the gas system checked for leakage. Make corrections needed before using again.
7. Never use a match, candle, or other open flames to check for gas leaks.
8. Failure to respond to a gas odor may result in property damage, personal injury or death.

### **OIL**

Homes that are equipped with oil burning furnaces must have oil supply piping installed and tested on site by a qualified professional in accordance with NFPA 31, Standard for the Installation of Oil Burning Equipment, 2001 or the requirements of the LAHJ, whichever is more stringent. The home manufacturer does not supply oil piping or tanks.

#### **OIL CONNECTION**

Consult the furnace manufacturer's instructions for proper pipe-sizing and installation procedures. Where piping is run through the bottom of the home, ensure all holes in the bottom board are sealed tight with foam, mastic, and/or tape specially made for that purpose and made rodent proof.

When equipping the home with an oil storage tank, comply with the following:

- Install the pipe with a gradual slope toward the fill end or drain plug (if so equipped) to facilitate pumping or draining of water and sludge.
- Provide a readily accessible approved manual shut-off valve at the outlet, installed to close against the supply.
- Equip the tank with an approved oil filter or strainer located downstream from the tank shut-off valve. Use a filter or strainer containing a sump with a drain to trap water.
- Equip under ground tanks with a filler neck extending one foot above grade and minimum 1 1/4 inch diameter vent pipe extending at least two feet above grade.
- Locate the tank to be accessible for service and inspection, and safe from fire and other hazards.
- Oil storage tanks and pipe installations should meet all applicable local regulations.
- In flood hazard areas, the oil storage tank should be anchored and elevated to or above the design flood elevation, or anchored and designed to prevent flotation, collapse, or permanent lateral movement during the design flood.
- Install tanks that feed vaporizing type oil furnaces so that oil flows by gravity. To achieve efficient gravity flow, make sure that the bottom of the tank is at least 18 inches above the furnace oil control level.
- Tanks for gun type oil furnaces (these furnaces include a fuel pump) may be installed above or below ground.
- Never use fuels, which are not recommended for use by the furnace manufacturer.

#### **OIL SYSTEM TESTING**

Before operating the system, fill the tank to capacity with the fuel to be burned and visually check all joints in the system for leakage. Replace (do not repair) parts that leak.

## **6-9 HEATING AND COOLING SYSTEMS**

The air circulation system of your home has been designed to operate cleanly and efficiently and to provide a supremely comfortable living environment. The heat can be controlled by use of the thermostat and by individually adjusting the vent openings in each room so that an equal amount of air is coming from each register. Each register is equipped with an adjustable damper which will allow the system to be balanced. Only by balancing the system can you achieve an even heating or cooling. This balancing process is wholly within your control.

As the furnace blower is operating; heated air is forced through the duct system and into your home through the adjustable damper registers. This is the supply air. The return air, or cold air, is returned across the floor of your home back to the furnace front and into the furnace blower compartment where it is once again forced past the heat exchanger to be warmed and into the duct. The return of cold air across the floor to the furnace may feel like a cold draft. This, however, is not the case and should not be alarming to you.

During the heating season when the furnace is operating, the air temperature within the heat duct can fluctuate to 150° F, more or less. If sustained contact between the human body and a register is allowed, the heat build-up could cause serious injury. Never place an infant or person who could be incapacitated on or near a heat register or in a position where they could fall or be immobilized on the register for any period -- like with a heating pad -- severe burn could result.

Heating and air conditioning units are installed according to the instructions and procedures recommended by the manufacturer of each specific unit and should require a minimum of maintenance and service. Each manufacturer has supplied an instruction booklet that details the operation, care, and maintenance procedures of each particular heating or air conditioning unit. Read these booklets carefully and file them in the back of this folder for future reference.

### **FURNACES**

The most important single maintenance operation regarding the heating system of your home is keeping a clean furnace filter. Dirty filters cut down drastically on the heating capability of a furnace, besides increasing fuel use and reducing the operating life of the furnace. The furnace and furnace enclosures are not for storage. **DO NOT** store anything on top, in front of, or beside your furnace as this will create a fire hazard and will affect the return air system.

### **GAS FURNACE**

Gas heating systems utilize either natural or liquefied petroleum (bottled) gas. The size of the orifice (the mouth-like fitting at the end of the pipe that regulates gas flow) varies with the type of gas used. It is important that the proper size for your system be installed. These furnaces are fully automatic and employ a safety pilot light or automatic ignition. All adjustments should be made by a qualified serviceman.

### **OIL FURNACE**

Oil furnaces function automatically and incorporate various safety devices. Little operating knowledge is required. However, particular attention should be paid to the manufacturer's lighting instructions. If adjustment is required, contact a qualified serviceman.

**CAUTION:** Only the recommended grade of fuel oil should be used. Never add gasoline or Naphtha to the fuel oil.

### **ELECTRIC FURNACE**

Electric furnaces are simple to operate and require little attention other than filter maintenance. It is important however, that your power company provides adequate energy to operate the furnace efficiently.

### **AUXILIARY HEATERS**

Kerosene, electric, and other space heaters are often the cause of fires in both manufactured and site built homes. Children can interfere with their proper use and these heaters add unduly to the humidity in your home. For these reasons, this company recommends that you avoid their use. Your home is well insulated and has an excellent heating system and should not require supplemental heating, which can be dangerous.

Every appliance you bring into the home should be operated strictly in accordance with the installation and instruction manuals associated with that fixture or device. These should not be used when people are sleeping.

## **AIR CONDITIONING**

Factory installed air conditioning is properly wired and fused. If air conditioning is installed at a later date, the following details should be considered:

1. The addition of an air conditioner, as well as any other major electrical appliance, will put an extra load on your home's electrical system. A qualified electrician should always be consulted when planning new installations.
2. If the air conditioning unit is intended to operate throughout the air distribution system of the home, careful attention must be paid to the minimum size necessary and the maximum allowable size for a specific home as stated on the Heating and Cooling Design Basis Certificate.
3. If a remote system (com-presser and blower outside the home) is installed, automatic dampers must be installed between the furnace and the home's air duct system, and between the air conditioner and the home's air duct system.
4. If your home has been factory fitted for remote A/C, connect the ducts via the protrusion from the bottom of the home.

This provision prevents the flow of warm furnace air out of the air conditioner when the furnace is operating and likewise prevents the flow of cool air out of the furnace when the air conditioner is working. The air conditioner supplier should have these dampers available and will provide proper installation instructions. The duct connecting the remote system to your home must be securely supported and should not contact the ground. The ducts must have an R (thermal resistance rating) of 4 and a perm rating of not more than 1 perm. Follow all manufacturers' instructions when you connect duct supply and return.

**CAUTION:** Maintaining an inside temperature at or below the dew point during the cooling season, may cause condensation, in the form of water, to form on the backside of your floor and/or exterior wall and ceiling panels resulting in water damage, and promoting the growth of mold and mildew.

## **6-10 WATER AND DRAINAGE SYSTEMS**

The water inlet pipe of your home is a standard 3/4" pipe. At the time of installation a water supply line is connected to the inlet pipe of the home. A shut-off valve is necessary in order to isolate the water source for the purpose of making repairs or performing maintenance to your water supply system.

The water lines of your home were factory tested at a pressure of 100 pounds per square inch (psi). The system was engineered to operate at a pressure not exceeding 80 psi. If the line pressure at your particular home site exceeds 80 psi, a pressure-regulating valve must be installed at the water inlet so as to limit the pressure to a maximum of 80 psi.

In areas where temperatures fall to the freezing point or below, the water supply line and sewer lines should be installed below the frost line and all exposed piping must be protected from freezing.

This company recommends that all exposed water piping subject to freezing be protected with a listed heat tape wrapped with fiberglass insulation (do not use vinyl foam insulation). All exposed sewer lines should also be protected in the same manner. The listed heat tape must be installed in accordance with its installation instructions. An exterior receptacle has been provided under your home near the water inlet for use with the heat tape.

## **6-11 MAJOR APPLIANCES AND WATER HEATERS**

Nationally recognized brand name appliances have been factory installed in your home. Each appliance has been provided with an "operation, care, and maintenance" booklet along with the specific warranties. All warranties should be filled out and mailed immediately, and the serial numbers of all units should be recorded for future reference.

### **WATER HEATERS**

Water heaters, whether they are gas or electric, require very little attention. They are equipped with internal thermostats to maintain the water temperature at the desired level. The temperature setting is normally 120° F (a minimum of 120 F is required for automatic dishwashers). All storage (tank type) water heaters are

equipped with pop-off pressure relief valves as a back up in case of thermostat failure. These valves should be checked at time of installation to make certain that they are free to function properly.

Water heaters have the ability to heat water to temperatures exceeding 125°. If sustained contact between the human body and high temperature water is allowed, the heat build-up could cause serious injury. Always feel the water temperature before bathing or showering yourself or those in your care.

### **ELECTRIC WATER HEATERS**

Electric water heaters must be filled with water prior to supplying electric power so as to prevent damage to the heating elements. Check electrical power requirements before installing a new water heater so as to prevent any branch circuit overloads or reduced heating capacity.

Prior to draining the water from the water heater as part of a winterization program or to service the appliance the electrical power supply must be interrupted. To interrupt the power supply, turn the circuit breaker located in the panel board to the "OFF" position. Where the panel board is not within sight of the appliance, a handle-locking device should be applied to the circuit breaker handle to ensure that it cannot be accidentally switched to the "ON" position thus energizing the circuit. These devices are available where circuit breakers are sold.

**CAUTION:** if your home is equipped with an electric water heater, do not turn on the circuit breaker in the distribution panel until after the water heater has been filled with water. Energizing the circuit prior to filling the water heater will result in severe damage to the heating element within the water heater.

### **GAS WATER HEATERS**

Gas water heaters should not be ignited until filled with water. Make certain the proper sized orifice is installed for the type of gas being used. Building codes and manufacturers specifications fix combustion air requirements for these units. Combustion air is provided by means of a floor vent. **DO NOT**, under any circumstances, block this vent.

### **CLOTHES DRYERS**

If your home has been wired for an electric dryer, then provisions have been made for a dryer vent. Completion of the venting hook-up is the responsibility of the owner.

The hook-up procedure is as follows:

1. Locate the vent pipe that has been installed in the floor of the laundry area.
2. Remove the vent pipe top cap.
3. Connect the dryer vent to the floor vent pipe by means of 4-inch flexible tubing.
4. Locate the vent opening underneath the home.
5. Attach tubing to exit point of vent pipe.
6. Suspend tubing by means of rust proof straps attached to bottom of floor and run to exterior of home through the skirting or foundation wall.
7. Install exhaust hood (damper vent) above the local snow level.

**WARNING!** Dryer exhaust system must terminate beyond the edge of the foundation or skirting of the home, never inside or beneath the home. Use only metal or metal flexible duct; coiled wire covered with a plastic or foil material is unacceptable.

### **FIREPLACE**

Sections of the flue (chimney) were not installed in the manufacturing facility due to transportation height restrictions.

**WARNING!** Do not operate the fireplace until all sections have been assembled and installed in accordance with the manufacturer's instructions.

Make certain you read your fireplace operating instructions before the first use of the fireplace. In addition to the instructions, never burn charcoal, coal, or sappy wood as they can burn at too high a degree and burn out or destroy the insulating integrity and cause the accumulation of tars, which result in dangerous flue fires. This fireplace should not be used as the principal heating system of your home or even the room it is located within. Never overstock the fireplace with combustible material or leave the fire unattended. Keep the fire on the grate to the rear of the fireplace. Have the fireplace and flue inspected between spring and

fall, and any worn or distorted firewalls or cracked firebrick replaced. Replacement parts are available from the fireplace manufacturer.

### **6-12 SHUT OFF VALVES**

All natural and LP gas burning appliances are factory equipped with shut off valves on the fuel lines. These valves are located inside the home within a few feet of the appliance. They may be located behind cabinet doors, drawers, or behind a removable panel. Be sure to make yourself aware of their location and use. It requires only 1/4 turn of the handle to turn the valve off and cut the fuel supply.

### **6-13 EXIT DOORS**

Every home is designed to the U.S. Department of Housing and Urban Development Manufactured Home Construction and Safety Standards with two exit doors which are remote from one another. Be sure that these doors are operable and left free for exit.

It is your responsibility to ensure that all exterior doors open onto properly sized porches or stoops which have been provided with guard rails and handrails maintained in a good condition. Under no circumstance should a condition be allowed to exist where there is a free fall from a door opening to the ground below.

### **6-14 HIGH WIND PRECAUTIONS**

Homes located in Wind Zones II and III may occasionally be subjected to high winds. In the event of high wind, you may wish to protect your primary windows, patio doors, and entrance doors against the pressures created by high winds. If you have not already installed storm shutters, these areas may be protected by a covering of plywood fastened to the wall studs around the window or doorframes with wood screws. Any joints in the plywood at patio door openings will need to be secured by fastening a 2 x 4 to each side of the plywood to stiffen the joint. When the plywood is removed, the screw holes must be filled with a high quality silicone caulk. Such caulking is available at local retail stores.

Receiving devices, sleeves, or anchors for fasteners to be used to secure shutters or other type of manufactured protective covers to the exterior walls at window and door locations have not been provided with this home.

When the wind force is high enough to require the protection of your windows and doors as described above, it is recommended that you seek shelter away from the path of the storm or in specifically designated shelters.

### **6-15 AIR INTAKES**

Fuel burning appliances such as your furnace, water heater and fireplace are equipped with air intakes that provide the air the appliance needs for the proper combustion of the fuel they burn. The air intake for the furnace is built into the chimney while the air intake for the water heater and fireplace are usually under your home, but may also be located through an exterior wall.

If your home was placed on a basement, it is important that you confirm that the combustion air intakes for any fuel burning appliances, which normally draw their combustion air from under the home, have been extended to the exterior side of the foundation walls.

A fresh air intake is located within a few feet of the vent flue for your furnace. For homes equipped with an electric furnace, the intake will be located on the roof above the furnace location. The intake is connected to the furnace through an air duct allowing for the introduction of fresh air into your home as the furnace operates during the heating season and during the cooling season, where air conditioning equipment has been installed, automatically conditioning the incoming air. During the in between times fresh air can be introduced by operating the ventilation switch on your thermostat which actuates the furnace blower.

It is important that the area around these intakes is cleared of snow or other material, which may build up around them blocking these intakes, on an ongoing basis as part of your home owners maintenance program.

## **INSURANCE**

### **7-1 GENERAL**

Insurance coverage and rates for manufactured homes vary from state to state as a result of their different regulations. It is your responsibility to make certain that you have adequate coverage for any possible loss.



Your insurance plan should be re-evaluated on an annual basis to confirm that your coverage is equal to any potential loss.

The kinds of coverage you need should be discussed with an agent of your choice who represents an insurance company that understands the manufactured home and can help plan a program best suited to your needs.

There are certain basic principles and fundamental information about insurance that apply to all kinds of home ownership--manufactured or site built.

Insurance companies have given recognition to the problems of the manufactured home owner so that adequate protection is possible both when the home is in transit or sited.

If you plan to relocate your manufactured home, be sure to ask your transport company which aspects of the move will be covered by his insurance. You may wish to obtain temporary additional collision or upset "trip" insurance, or to insure specific items in the manufactured home for possible transit damage.

Included among the types of insurance that the homeowner should be aware of are four basic types of insurance that you may want to consider. This list is included to help you select adequate coverage, but there may be additional types of coverage, which you should consider.

### **7-2 COMPREHENSIVE PHYSICAL DAMAGE.**

This type of insurance pays for certain kinds of direct damages to your property such as flood, fire, theft (of your home), earthquake, windstorm, landslide, and lightning. Other damages might be included such as spillage of inks, chemicals, paint, oils, faulty thermostatic controls, etc.

On-the-road collisions or upsets would not be included in this category, but could be insured separately as could natural disaster protection which would pay off the loan in the event the home is destroyed before all payments are made.

It would be well to determine whether adjacent structures (such as steps, awnings, carports, skirting, air conditioning, and utility buildings) are automatically considered a part of the "comprehensive" physical damage policy.

Be sure to check if personal effects may also be included, whether or not they are in the manufactured home at the time of destruction or disappearance. If you have collections, art, antiques, jewelry, or other valuables, determine whether or not they are automatically on your policy or must be declared separately.

Other items, which could be included, if desired, are:

1. Living expense coverage when the home cannot be lived in because of an insurance loss.
2. Emergency removal of the home to safety and back if there is a threat of loss.
3. Fire department service coverage if there is a charge.
4. Radio or television antenna or satellite dish loss or damage.
5. Damage or destruction of landscaping.
6. Damage to anchoring system.

### **7-3 LIABILITY INSURANCE**

This type of insurance pays damages to someone else should an accident for which the owner was responsible occur on his property. Such damages could include court costs, first aid and emergency treatments, lost wages, medical and dental costs, and other items agreed upon.

### **7-4 CREDIT LIFE INSURANCE**

This type of insurance pays off a loan (on the manufactured home) if the homeowner should die, except by suicide, before the home is paid for.

### **7-5 CREDIT ACCIDENT AND HEALTH INSURANCE**

This type of insurance provides for the continued payment of loan installments in case the owner cannot work because of illness or an accident, up to the policy limits you purchase.

## 7-6 OTHER CONSIDERATIONS

Some additional items to consider in buying manufactured home insurance are:

1. Total coverage received for money paid.
2. Comprehensive coverage that insures the home for direct or accidental loss.
3. Prompt and capable claims handling.
4. Guaranteed renewal.
5. Agent's knowledge of insurance needs of manufactured homeowners.

## SPECIAL INFORMATION

### 8-1 INSTALLATION PROCEDURES

Correct installation procedures are absolutely essential if your home is to perform correctly. This work should be done by a competent installer. Your retailer can normally provide this service. You will find instructions for the installer to follow in the package that contains this manual. After the manufactured home installation has been completed, we recommend that it be professionally inspected to assure that it has not been damaged in transit and is properly installed.

Your retailer should have provided the installation instructions which came with your home for your use. This manual contains important information which you will need should you decide to relocate your home. If you did not receive your copy of the installation instructions, contact your retailer requesting that he provide your installation instructions as soon as possible. **Please read the installation instructions.**

### 8-2 SETTLING

Since a manufactured home and its foundation are built apart from one another, there will be a period of time after the home is installed, during which they will settle in together, each giving and taking a little. This initial settling is normal and usually requires a realignment of the home on its foundation, usually in about 8 weeks.

A properly maintained installation will, under normal conditions, prevent the home from settling and avoid the possibility of incurring expensive repair bills. If your home is not set and maintained in proper alignment as it was designed, or if it is not set on a completely firm and proper foundation system as described in the installation manual, certain portions of your home will undergo undue and unnatural structural strain. Such structural strain could lead to problems later. Typically, these problems appear in the form of buckling, loosening, or separating of wall coverings, exterior siding, floors and their covering, ceilings, metal roof membranes and miscellaneous fixed original fixtures and cabinets in the home. Other problems relating to installation include the leaking of doors, windows, roofs, ceilings, and exterior walls due to the loss of the weather seals in these areas, as well as the loss of proper operation of windows and doors and their locking devices. The alignment and supporting piers must be checked on an annual basis as part of your owners maintenance program.

Should this problem occur, contact your retailer or installer for an inspection of the installation and have the unit realigned as needed.

### 8-3 SKIRTING

Skirting of your manufactured home is recommended. Not only does it improve the appearance of the home, but it also reduces the energy used to heat and cool your home and keeps animals from under the home. Animals can cause damage to any exposed electrical lines, water lines, gas systems, bottom board, exposed heating and cooling ducts, etc.

Skirting is any structural or non-structural perimeter crawlspace enclosure. Skirting must not be attached in a manner that can cause water to be trapped between the siding and the trim or forced up into the wall cavities to which it is attached. Skirting must not be attached in a manner that impedes the contraction and expansion characteristics of the homes exterior covering.

Skirting must be of weather-resistant materials or provided with protection against weather deterioration at least equivalent to that provided by a coating of zinc on steel of not less than 0.30 oz per sq ft of surface coated. Skirting made from wood or wood products and used within six inches of the ground needs to be made of materials naturally resistant to decay and termite infestation or pressure be treated in accordance with AWWA Standard U1 for Use Category 4a, Ground Anchor Contact Applications.

The area beneath your home must be ventilated. The minimum vent area shall be one square foot of net free area (area of opening in grillwork) for every 1,500 square feet of area under the home. (Length of home multiplied by width of home divided by 1,500 equals net free area of vent required in square feet.) Install an equal number of ventilators along each side of the home. One ventilator should be within three feet of each end of the home with the remainder equally spaced along the length of the home and located across from one another. This will allow for cross-ventilation and dissipate damaging condensation.

The area under your home and enclosed by the skirting is not intended to provide storage for flammable materials or liquids. These items must never be placed under the home because they place the occupants and the home in danger.

#### **8-4 MOVING**

Manufactured homes are moved by professional manufactured home movers. There are several firms that specialize in this activity, and they have offices in all major cities.

While you should never attempt to move your home yourself, there are certain procedures that you should follow to prepare for the move.

**NOTE:** It is extremely important to consult with a professional manufactured home mover about the weight and load distribution prior to moving to prevent impairing the home's structure.

#### **8-5 ROAD GEAR INSPECTION**

##### **HITCH COUPLER ASSEMBLY**

Your home is equipped at the front with a coupling and hoisting device called a hitch. This provides a means for attaching the home to the towing vehicle.

Grease fittings or oil points are provided on most couplers for lubricating the jack mechanism to prevent rusting and to provide for easier operation. Regular greasing and cleaning of the mechanism is advisable so the parts will be functioning when they are being used.

##### **BRAKES**

A home that has been parked for a prolonged period should have its brakes checked by a competent manufactured home automotive mechanic before being moved over the highway. Electrical connections should be checked to make sure they are clean and tight, or the result may be weak, uneven, or grabbing brakes, or a lack of brakes. Linings should be replaced immediately when they become worn out or greasy. Linings approved by the manufacturer of the brakes should be used.

##### **TIRES**

When a home is blocked in position, tires should carry some of the weight but a board should be placed under the tire to keep it free of the soil. Tires should be kept inflated.

After the home is positioned and the skirting is installed, the tires will be shielded from the sun. Painting the tires with a rubber tire paint helps protect them from deterioration.

The original tires furnished with your home are guaranteed by the tire manufacturer to be free from defects in workmanship for a certain period of time. Check the tire warranty information. If an examination shows that any tire has failed under the terms of the warranty, adjustment should be arranged through the nearest tire retailer handling that brand of tire.

All tires are designed to carry a specific load at a specified air pressure. They will render satisfactory service if used within the load limitation indicated by the tire manufacturer.

##### **WHEELS**

Wheel bearings can become badly etched or corroded when your home is parked for long periods unless the bearings are well covered with a protective covering of a suitable lubricant.

Corrosion is caused by water getting in through the seals or by moisture, due to condensation, forming in the hub with variations in temperature. There is no way to prevent the condensation except to fill the hub and

bearings completely with grease. After your home has been permanently located, the wheel bearings and the hub should be cleaned and repacked with grease, leaving no voids in the hub to prevent the entrance of moisture.

If your home is to be moved on the highway again, some of the grease should be removed so that the hub is about two-thirds full. This will prevent grease leakage through the seals to the brakes. If the hubs are left fully packed, the grease will expand from heat generated at higher speeds and will be forced through the seals. This can cause faulty brake operation.

It is important that the wheel bearings be inspected and cleaned prior to moving.

To check for spindle tightness, the grease cap under the hub should be removed. The spindle nut should be pulled up tight, then backed off to the first cotter pin hole so that the wheel will rotate freely when jacked up. No side play should be present in the bearings. This can be checked by rocking the wheel sideways by hand with the wheel jacked up.

### **8-6 REINSTALLATION OF ROAD GEAR**

In many cases, the hitch coupler assembly, axles, wheels, and tires are removed from manufactured homes at the time of installation and are placed in storage. Many times, the axles, wheels, and tires are retained by the retailer as part of the purchase contract or are sold to an after market vendor. When these items are reinstalled, it is important to ensure that the original equipment is inspected as discussed earlier in this section, and that any replacement items are equal to the original equipment. You should record the required information in the rear of this manual for later reference.

### **8-7 PACKING**

Pictures, clocks, radios, small television sets, lamps and other fragile items can be tied on the couch in the living room or on a bed. Anything loose will slide forward on a quick stop. Some people prefer to put these small items in cartons.

Dishes should be packed in cartons with towels and pillows. If latches are inclined to jolt open, use masking tape to secure them.

**CAUTION:** It is strongly recommended that you consult with a professional manufactured home mover about the load and weight distribution within your home prior to moving. Since loose articles within a moving home tend to shift to the front and to the right, most of the weight should be placed against the forward walls.

Heavier and unbreakable items should be packed over the axle to the front, with the weight evenly distributed to the center of the home. Place as few items as possible in the rear rooms.

The water inlet and sewer outlets should be capped. Close all windows. Lock all doors. The mover should check the entire undercarriage of the home and the tires for proper inflation.

### **8-8 OVERLOADING**

Remember, overloading means overweight, unnecessary stress, and under carriage sway--all of which result in extra cost to you for tire blow-outs, structural damage, and longer routing.

Check and make sure after loading that the distance between the top of each tire and the bottom of each wheel well is three inches or more. This will prevent a dangerous rubbing of tires when the home is moving.

Prior to moving, a good rule of thumb is to take out everything that was not on the home's original factory invoice except for your normal clothing supplies. Your home was not built to haul cargo. Do not carry such things as blocking apparatus, blocks, lawn mowers, or lawn equipment in your home when moving.

Items such as a piano, freezer, or large trunks should be shipped separately. Your home as been designed and constructed to be capable of sustaining the design loads, considering of the dead load plus a minimum of three pounds per square foot floor load in the superimposed dynamic load resulting from the over-the-road movement.

Excessive weight or improper weight distribution while towing your home to another site could possibly cause the home's under-frame to bend or misalign during transit. As a result, the whole structure of the home could be impaired, and the same four general conditions resulting from improper blocking and leveling of your home could also occur immediately or gradually after any secondary moves of the home.

## **8-9 ROUTING**

Make sure you and your manufactured home mover map out a smooth route to the new location of your home. Your home should not be towed over a rough, dirt, or gravel road. It should not be towed at excessive speeds.

## **8-10 WARRANTIES AND WARRANTY SERVICE**

Specific provisions for the warranty on this home are covered by the separate warranty information contained in/with this manual. In addition to the basic warranty on the home, many appliances such as the furnace, washing machine, etc., supplied with the home will have separate warranties and operating instructions manuals. We suggest that you locate and familiarize yourself with these items. For your convenience, some of the separate appliance warranty manuals are contained in the information package. In other cases, such as furnaces and water heaters, the operating instructions (which may contain the warranty information) are required to be attached to the appliance.

If local service is requested under the terms of your warranty, you should become familiar with the appliance service representative. It is suggested that this information be recorded in the back of this manual under the section entitled, "Your Local Service References." The retailer from whom you bought your home can probably provide this information, or it can be obtained from the manufacturer of the appliance.

At the time you move into your home, please complete and return a Homeowner Information card and a warranty card if your retailer has not already done so. This information will aid in contacting you or a subsequent owner if the need should arise.

As stated above, the specific provisions for the warranty on this home are covered by the separate limited warranty information contained with the manual. We urge you to read the warranty carefully so that you will fully understand the coverage provided, what is not covered, as well as any terms or conditions of the warranty. If you do not have a copy of the warranty, please contact your retailer or this company at the address listed on the front of this manual to obtain one.

For warranty service on your home, we ask that you take the following steps:

As to any part or appliance or device warranted by its manufacturer, please contact the nearest service center indicated in its separate warranty.

As to items warranted by this company or the retailer, an initial request to your retailer will enable them to advise this company of the problem if the retailer is of the opinion that the problem is related to the manufacturer and covered by your warranty.

If the retailer does not obtain for you, in a reasonable time, the satisfaction you believe you are entitled to under your warranty from this company, please contact the Director of Service at the address shown on the front of this manual by certified mail. We will service any warranty concern directly. If a dispute between the retailer obligation and the manufacturer obligation is involved, a meeting at your home will be arranged.

Be sure to protect your warranty period by written notice directly to this company if at any time your warranty period is close to expiration and a warranty-protected concern is involved.

## **8-11 PREVENTIVE MAINTENANCE**

As the homeowner, you must recognize that your home will require a certain amount of preventive maintenance to keep it in good condition. You should make any minor adjustments to your home which you are capable of doing, such as setting high fasteners in wall paneling, re-nailing loose trim and moldings, tightening a leaking water connection or a leak at the p-trap under a sink or resealing a loose shingle tab with asphalt plastic cement. You should also establish an ongoing homeowner maintenance program to ensure the long term well being of your home.

The electrical, heating, and plumbing systems of your manufactured home were designed and installed in accordance with accepted engineering practices. However, normal use through time will cause some expected breakdowns on components just as would happen in any other building or home. To prevent major problems, watch for telltale danger signals such as continuous damp areas under drain and water lines, oil or gas leaks in your fuel system, overloading of electrical circuits resulting in a circuit breaker continuously tripping off, or the unusual flickering of lights. Become acquainted with the Use and Care manuals provided by the appliance manufacturers and follow their instructions as closely as possible.

If a breakdown does occur, consult a local tradesman specializing in the specific area of trouble. Complete the information requested in the Directory of Service Firms (on the following pages) as soon as possible so that you will have a ready reference in case of emergency.

If your home is equipped with gas appliances, a shut-off valve is installed within 6 feet of the appliance, closing the valve will terminate the gas flow. You should familiarize yourself with their locations which may be behind a drawer bank, base cabinet door, or access panel. The electric distribution panel has a main shut-off switch to be used if it is ever necessary to cut off electricity throughout the house. The main shut-off valve for the water system is usually located in the area of the water heater under the home. This should be shut off if any break occurs in the water system.

## **8-12 THE DATA PLATE**

The manufactured home Data Plate is located near the electrical panel, in a kitchen cabinet, or in the master bedroom closet. The Data Plate could be divided into four basic parts. See Section 2-1 in the Installation Manual. Each part and its information are as follows:

The first part lists the manufacturer name and address, date of manufacture, description of the home, its serial number, and the agency who approved the overall design and structure of the home.

The second part lists all the major appliances that were factory installed. It should be noted that all these appliances are covered by their manufacturers' warranties and not by this company.

The third section identifies the structural zones the home was constructed for:

1. Design Roof Load Zone. The design roof load is indicated by the shaded areas on the map and the labels, North, Middle, and South. These areas are based on the amount of snowfall that a given area could receive. It is not recommended that your home be relocated into an area with a larger PSF rating than the one marked.
2. Design Wind Load. The design wind load is indicated by the zones shown on the map. These zones are based on the amount of force generated by the wind and applied against the side of the home. It is not recommended that your home be relocated into an area having a greater wind load than the one indicated. Refer to this map to determine the proper tie-down system to use.

The fourth and last part covers the heating and cooling design of your home. It will indicate which winter zone the home has been designed for, the lowest outside temperature at which the furnace will maintain a +70° F inside, and the largest size air conditioner that the duct work can handle. The heat gain "U" values are also listed to enable an air conditioning contractor to size an air conditioner to your home. It is not recommended that your home be relocated into an area having a colder climate than indicated on the map.

## **8-13 ATTIC STORAGE SPACE**

If your home has an attic storage space you must make certain to safeguard it to prevent pets, children of all sizes, adults, and yourself from stepping or falling off onto any unfloored portion of the attic. You can do this by ensuring that the flooring has been installed between the knee walls and into each dormer, where provided. Such an incident could cause personal injury and may damage the ceiling of the habitable space below. Keep the access door locked and the key in a safe place away from children. Appropriate steps must be taken to prevent access to any area not covered by a sound flooring system by installing a suitable barrier on the surface of the knee walls. Attics are not a habitable space.

## **8-14 U.S. DEPARTMENT OF HOUSING AND URBAN DEVELOPMENT**

HUD is the federal agency which administers the Act and any questions concerning the Act or your rights under the Act can be directed to HUD or to the approved State Administrative Agency (SAA) in your state acting as HUD's agent. In order to contact HUD, you should refer to the Department of Housing and Urban Development under listings for the U.S. Government in your telephone book. In calling or writing the local HUD office, you should address your inquiry or call to the "Consumer Complaint Officer." If you live in a small town or rural area, your local HUD office will probably be located in a nearby city. You may also contact the central HUD office directly by writing or calling the Office of Manufactured Housing Programs, Office of Regularity Affairs and Manufactured Housing and Urban Development, 451 Seventh Street, SW, room 9164, Washington DC 20410-8000, Telephone (202) 708-6423 or (800) 927-2891.

## 8-15 STATE ADMINISTRATIVE AGENCIES (SAA)

<u>Alabama-</u>	Manufactured Housing Commission, 350 S. Decatur St., Montgomery, AL 36104-4306, 334-242-4036
<u>Arizona-</u>	Department of Building & Fire Safety, Office of Manufactured Housing, 100 East Capitol Street, Suite #210, Phoenix, AZ 85004-1108, 602-364-1003
<u>Arkansas-</u>	Manufactured Home Commission, 523 S. Louisiana St., #500, Little Rock, AR 72201-5705, 501-324-9032
<u>California-</u>	Department of Housing & Community Dev., Division of Codes & Standards, Manufactured Housing Section, 1800 Third Street Suite 260, Sacramento, CA 95814-6900, 916-445-3338
<u>Colorado-</u>	Housing Division, Department of Local Affairs, 1313 Sherman St., #321, Denver, CO 80203-2244, 303-866-4616
<u>Florida-</u>	Bureau of Mobile Homes & RV's, Division of Motor Vehicles, 2900 Apalachee Pkwy, Room A-129, Tallahassee, FL 32399-0640, 850-488-2808
<u>Georgia-</u>	Manufactured Housing Division, State Fire Marshal, #2 Martin Luther King Jr. Dr. #620 West Tower, Atlanta, GA 30334, 404-656-3687
<u>Idaho-</u>	Division of Building Safety, Building Bureau, 1090 E. Watertower Street, Meridian, ID 83642, 208-332-8991
<u>Illinois-</u>	Illinois Department of Public Health, Division of Environmental Health, 525 West Jefferson Street, Springfield, IL 62761, (217) 782-5830
<u>Indiana-</u>	Code Enforcement Division, Department of Fire & Bldg. Services, 402 W. Washington St., Room W-246, Indianapolis, IN 46204, 317-232-1407
<u>Iowa-</u>	Iowa State Building Code Bureau, Department of Public Safety, 215 East 7 <sup>th</sup> Street, Des Moines, IA 50319-0047, 515-725-6140
<u>Kentucky-</u>	Manufactured Housing Division, Kentucky Fire Marshal's Office, 101 Sea Hero Road, Suite 100, Frankfort, KY 40601-4322, 502-573-0365, ext 425
<u>Louisiana-</u>	Manufactured Housing State Administrative Agency, Louisiana Manufactured Housing Commission, 11606 South Fork Ave., Suite 103, Baton Rouge, LA 70819-5235, (225) 265-8500
<u>Maine-</u>	Manufactured Housing Board, Department of Professional and Financial Regulations, 35 State House Station, Augusta, ME 04333-0035, 207-624-8678
<u>Maryland-</u>	Department of Housing and Community Dev., Maryland Code Admin., 100 Community Place, Crownsville, MD 21032-2023, 410-514-7220
<u>Michigan-</u>	Bureau of Construction Codes, Office of Local Government and Consumer Services, 2501 Woodlake Circle, P.O. Box 30254, Okemos, MI 48864, 517-241-9347
<u>Minnesota-</u>	Department of Labor and Industry, Construction Codes and Licensing Division, Building Codes & Standards Division, 443 Lafayette Road North, St. Paul, MN 55155-4341, 615-284-5068
<u>Mississippi-</u>	Manufactured Housing Division, Office of the Fire Marshal, P.O. Box 79, Jackson, MS 39205, 601-359-1061
<u>Missouri-</u>	Missouri Public Service Commission, Manufactured Housing and Modular Units programs, 200 Madison Street, Suite 500, Jefferson City, MO 65102-3254, 800-819-3180
<u>Nebraska-</u>	Housing and Recreational Vehicle Department, Nebraska Public Service Commission, 1200 "N" Street, 300 The Atrium, P.O. Box 94927, Lincoln, NE 68509-4927, 402-471-0518

<u>Nevada-</u>	Department of Business and Industry, Manufactured Housing Division, 2501 E. Sahara Ave., Suite 204, Las Vegas, NV 89104-4137, 702-486-4579
<u>New Jersey-</u>	Bureau of Home Owner Protection, Dept of Community Affairs, P.O. Box 805, 101 S. Broad Street, Trenton, NJ 08625-0816, 609-984-7905
<u>New Mexico-</u>	Manufactured Housing Division, Regulation and Licensing Department, P.O. Box 25101, 2550 Collins Road, Santa Fe, NM 87504, 505-524-6320, ext. 107
<u>New York-</u>	Division of Code Enforcement and Administration, Dept of State, 11th Floor, Suite 1130, 41 State Street, Albany, NY 12231-0001, 518-474-4073
<u>North Carolina-</u>	NC Dept of Insurance, Manufactured Building Division, P.O. Box 26387, 322 Chapnoke Road, Suite 200, Raleigh, NC 27611, 919-661-5880, ext. 215
<u>North Dakota-</u>	North Dakota Department of Commerce, Division of Community Services, P.O. Box 2057, Bismark, ND 58502-2057, 701-238-5300
<u>Oregon-</u>	Department of Consumer and Business Services, Building Codes Division, P.O. Box 14470, 1535 Edgewater Drive, NW., Salem, OR 97309-0404, 503-378-4150
<u>Pennsylvania-</u>	Housing Standards Division, Department of Community and Economic Development, Commonwealth Keystone Building, 400 North Street, 4 <sup>th</sup> Floor, Harrisburg, PA 17120-0225, 717-720-7416
<u>Rhode Island-</u>	State of Rhode Island Building Code Commission, One Capitol Hill, Providence, RI 02908-5859, 401-222-3529
<u>South Carolina-</u>	South Carolina Manufactured Housing board, P.O. Box 11329, Columbia, SC 29211-1329, 803-896-4613
<u>South Dakota-</u>	South Dakota Department of Public safety, Office of the State Fire Marshal, 118 W. Capitol Ave., Pierre, SD 57501, 605-773-3562
<u>Tennessee-</u>	Department of Commerce and Insurance, State Fire Marshal's Office, 500 James Robertson Pkwy, Nashville, TN 37243- 1162, 615-741-7192
<u>Texas-</u>	Manufactured Housing Division, Texas Department of Housing and Community Affairs, P.O. Box 12489, 221 East 11 <sup>th</sup> Street, Austin, TX 78711-2489, 1-800-500-7074
<u>Utah-</u>	Division of Occupational & Professional Licensing, Department of Commerce, 160 East 300 South, Salt Lake City, UT 84111-6741, 801-530-6720
<u>Virginia-</u>	State Building Code Administration Office, Department of Housing & Community Development., Jackson Center, 501 North Second Street, Richmond, VA 23219-1321, 804-371-7160
<u>Washington-</u>	Factory Assembled Structures, Department of Labor and Industries, Installer/SAA Program, P.O. Box 44420, 7273 Linderson Way SW, Olympia, WA 98504-4220, 800-647-0982
<u>West Virginia-</u>	West Virginia Division of Labor, Manufactured Housing, State Capitol Complex, Building 6, Room B-749, Charleston, WV 25305, 304-558-7890, ext 237
<u>Wisconsin-</u>	Department of Commerce, Safety & Building, 4003 Kinney Coulee Road, LaCross, WI 54650, 608-785-9335

#### **8-16 OTHER INFORMATION**

We hope you are pleased with your manufactured home. Further information about it, including technical data, may be obtained by writing to the following address: Aftermarket Service Manager, Fairmont Homes, Inc., P.O. Box 27, Nappanee, Indiana 46550



**8-17 YOUR LOCAL SERVICE REFERENCES**

Your retailer can help you develop this list of local service contacts. Often the instructions received with separate appliances include information about local service. If you ever should need them, having the contacts listed here can save time and eliminate confusion during an emergency.

<b>YOUR RETAILER</b>	<b>GARBAGE DISPOSAL SERVICE</b>
Firm:	Model Number:
Street:	Make:
City:	Representative:
State, Zip:	Phone:
Serial Number of Your Home:	Warranty Expiration Date:
Year Purchased:	<b>RANGE SERVICE</b>
Serial Number of Keys:	Model Number:
Warranty Expiration Date:	Make:
<b>DRYER SERVICE</b>	Representative:
Model Number:	Phone:
Make:	Warranty Expiration Date:
Representative:	<b>DISHWASHER SERVICE</b>
Phone:	Model Number:
Warranty Expiration Date:	Make:
<b>AIR CONDITIONER SERVICE</b>	Representative:
Model Number:	Phone:
Make:	Warranty Expiration Date:
Representative:	
Phone:	
Warranty Expiration Date:	

**YOUR LOCAL SERVICE REFERENCES CONTINUED**

<b>FURNACE SERVICE</b>	<b>REFRIGERATOR SERVICE</b>
Model Number:	Model Number:
Make:	Make:
Representative:	Representative:
Phone:	Phone:
Warranty Expiration Date:	Warranty Expiration Date:
<b>HOT WATER HEATER SERVICE</b>	<b>WASHER SERVICE</b>
Model Number:	Model Number:
Make:	Make:
Representative:	Representative:
Phone:	Phone:
Warranty Expiration Date:	Warranty Expiration Date:
<b>WATER COMPANY</b>	<b>GAS COMPANY</b>
Name:	Name:
Phone:	Phone:
Emergency Phone:	Emergency Phone:
<b>ROAD GEAR INFORMATION:</b>	
Number of idler axles:	
Number of brake axles:	
Tire size:	
Axle capacity:	
Axle spring hanger centers:	

## **8-18 OWNERS PREOCCUPANCY CHECK LIST**

Make certain the home is set so that moisture runs away from the homes foundation or skirting rather than under it to avoid high humidity in the home, which encourages mold growth and a potentially unhealthy home atmosphere. It is essential that:

1. That in other than arid regions (see Installation manual) the ground beneath your home is completely covered with a minimum 6 mil polyethylene vapor retarder and that any damage has been repaired.
2. The ground beneath the home is sloped away from the center line to allow water to run off and not accumulate.
3. Confirm that the air conditioner and the water heater pan do not drain into the crawl space beneath your home.
4. Confirm that the clothes dryer exhaust pipe is a metal or flexible metal pipe, that it is properly supported, that it extends through the skirting or foundation wall, and that it ends with a manufactured hood (damper vent) above the level of any possible snow.
5. The bottom board is intact and any damaged areas have been properly repaired.
6. Make certain that the area beneath the home is adequately ventilated; one square foot of net free area (area of the holes in the ventilator) for every 1,500 square foot under the home.
7. Make certain that the grade around your home starting 2 feet inside the skirting is sloped away from the home in all directions at a rate of 1/2 inch per foot for the first 10 feet out side the skirting and that the site grading provides for water run-off.

The proper support of the home on the home site is very important to its well being in that settling and/or frost heave can affect the home in many ways as discussed earlier in this manual. Make certain that:

1. The footings in the ground are correctly sized and extend below the frost line or are frost protected in accordance with SEI/ASCE 32-01.
2. In the case of a floating pad, ensure that it is of the correct thickness and over all size and that it was constructed on a properly prepared site in accordance with SEI/ASCE 32-01. The annual realignment of the home on its supporting system may be required.
3. The supporting piers between the home and the footings do not exceed the maximum spacing as shown in the installation manual on the foundation drawings.
4. The marriage line supports for sectional units have been properly located and installed.

To resist the force of the wind, which can push the home from its foundation; it is imperative that the home be properly anchored to the ground or its foundation. Ensure that:

1. The materials used to anchor the home are correct for the purpose. Please refer to the installation manual.
2. The design has been followed with regard to the number of anchors. Their spacing and installation.
3. Any alternate system has been designed by a registered professional engineer or registered architect, approved by this company, and by this company's DAPIA.

## **8-19 SEASONAL MAINTENANCE AND CARE**

Seasonal maintenance and care of your home can add to your convenience and comfort. We have listed some key activities. You may wish to include other items to meet your needs.

### **SPRING**

1. Wash the exterior; vinyl and metal siding only.
2. Clean walls as needed.
3. Inspect the roof; remove debris including pine needles, leaves, and branches. Reseal around all roof openings where needed.
4. Check exhaust fan systems.
5. Check floors for alignment
6. Check blocking for rigidity.
7. Check wood fiber siding for insect damage and the need to be resealed.
8. Check door and window caulking seals for needed resealing.

### **SUMMER**

1. Check air conditioner.
2. Clean air filters.
3. Replenish fuel oil supply.
4. Check footings, piers, and the proper alignment of the home.
5. Inspect the fireplace and its flue.

6. Check for accidental or natural damage to shingles, roof vents, or siding; or the aging of weather seals on the roof, at doors and windows, siding or any other areas where moisture could enter your home.

#### **FALL**

1. Check and clean the furnace as needed.
2. Check fuel oil or LP gas supply.
3. Seal small openings
4. Inspect the roof.
5. Check exhaust fans.
6. Replace air filters.
7. Check the operations of heating cables.
8. Check and repair the insulative wrap on all exposed water drain and oil lines.

#### **WINTER**

1. Lubricate window hinges and arms.
2. Check furnace filters every 30 days.
3. Replace filters as necessary.
4. Check and repair the skirting around your home.
5. Maintain low humidity levels.
6. Clear excessive snow and ice from your roof.

**NOTICE**

**FEEDER MAKEUP AND GROUNDING METHOD FOR THIS MANUFACTURED HOME**

**NOTE:**

THE NEUTRAL IS INSULATED FROM THE GROUND IN THIS PANELBOARD. CONDUCTORS BETWEEN THE DISCONNECT AND THE PANELBOARD ARE REQUIRED TO BE CONTINUOUSLY INSULATED AND COLOR CODED INCLUDING THE GROUNDING CONDUCTOR. ALL FOUR FEEDER CONDUCTORS ARE ABSOLUTELY ESSENTIAL.

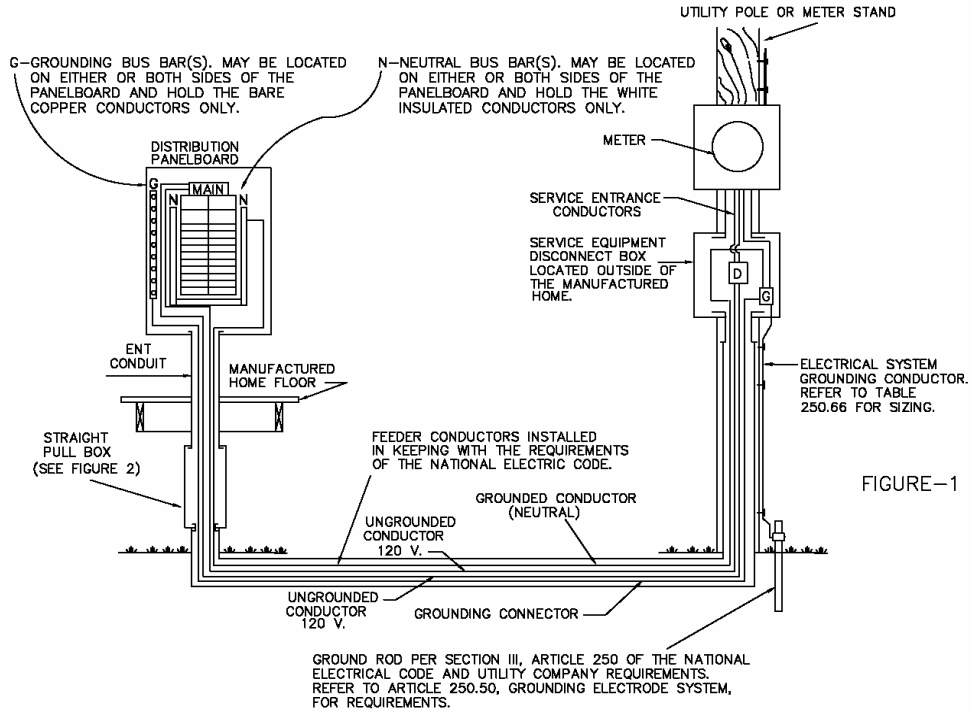

FIGURE-1

**CAUTIONS  
READ EVERY ITEM**

1. CONFIRM THAT THE GROUNDING CONDUCTOR IS CONNECTED TO THE GROUNDING BUS BAR AND THAT THE NEUTRAL CONDUCTOR IS CONNECTED TO THE NEUTRAL BUS BAR.
2. NEVER DOUBLE-UP ON A CIRCUIT BREAKER.
3. NEVER REMOVE COVER FROM ENTRY PANEL.
4. NEVER OVERLOAD A CIRCUIT.
5. NEVER ADD ADDITIONAL CIRCUITS TO THIS PANEL.
6. NEVER REPLACE A CIRCUIT BREAKER WITH ONE HAVING A HIGHER AMPACITY RATING.
7. NEVER CONNECT THE ENTRY PANEL TO THE DISCONNECT BOX WITH A MANUFACTURED LIFE LINE (PICTAIL CONNECTOR).
8. NEVER USE 3 WIRES IN PLACE OF 4. BECAUSE THE HOME WILL BE IMPROPERLY GROUNDED WITHOUT THE 4 WIRE CONNECTION THE CIRCUIT BREAKERS WILL NOT FUNCTION AND A SHORT CIRCUIT AT ANY TIME COULD CAUSE AN ELECTROCUTION.
9. TRIPPED CIRCUIT BREAKERS OF A PROPERLY CONNECTED SYSTEM INDICATE A SHORT CIRCUIT.

**WARNING**

THE FOURTH INSULATED CONDUCTOR, WHICH IS THE GROUND, IS ABSOLUTELY CRITICAL FOR SAFETY AND PREVENTION OF AN ELECTROCUTION IN THE EVENT OF A SHORT CIRCUIT.

ELECTRICAL FEEDER & EQUIPMENT SIZES						
FEEDER SIZE  SEE MAIN CIRCUIT BREAKER AND LABEL ON DISTRIBUTION PANELBOARD (AMPERES)	MINIMUM SIZES			FEEDER CONDUCTOR TYPE AND SIZES (AWG) 1, 2, AND 3		
	ANGLE OR U PULL BOX (IN)	STRAIGHT PULL BOX (IN)	ENT CONDUIT (IN)	UNGROUND CONDUCTORS	GROUNDED CONDUCTORS	GROUNDING CONDUCTORS
100	10x10x4	12x8x4	1 1/2"	NO.4 THN CU NO.2 THN AL	NO.4 THN CU NO.2 THN AL	NO.8 THN CU NO.6 THN AL
200	12x12x4	16x8x4	2"	NO.2/0 THN CU NO.4/0 THN AL	NO.2/0 THN CU NO.4/0 THN AL	NO.6 THN CU NO.4 THN AL

NOTES:  
 1. CONDUCTOR TYPE AND SIZES ARE IN ACCORDANCE WITH THE NATIONAL ELECTRIC CODE TABLE 310.15(B)(6).  
 2. COPPER OR ALUMINUM CONDUCTORS MAY BE USED WHEN PROPERLY SIZED IN ACCORDANCE WITH THE NATIONAL ELECTRIC CODE.  
 3. VOLTAGE DROP NOT CONSIDERED.  
 4. NATIONAL ELECTRIC CODE 2005 EDITION.

FIGURE-2

**NOTICE**

FEEDER MAKEUP AND GROUNDING METHOD FOR THIS MANUFACTURED HOME

**NOTE:**

THE NEUTRAL IS INSULATED FROM THE GROUND IN THIS PANELBOARD. CONDUCTORS BETWEEN THE DISCONNECT AND THE PANELBOARD ARE REQUIRED TO BE CONTINUOUSLY INSULATED AND COLOR CODED INCLUDING THE GROUNDING CONDUCTOR. ALL FOUR FEEDER CONDUCTORS ARE ABSOLUTELY ESSENTIAL.

G—GROUNDING BUS BAR(S). MAY BE LOCATED ON EITHER OR BOTH SIDES OF THE PANELBOARD AND HOLD THE BARE COPPER GROUNDING CONDUCTORS ONLY.

N—NEUTRAL BUS BAR(S). MAY BE LOCATED ON EITHER OR BOTH SIDES OF THE PANELBOARD AND HOLD THE WHITE INSULATED CONDUCTORS ONLY.

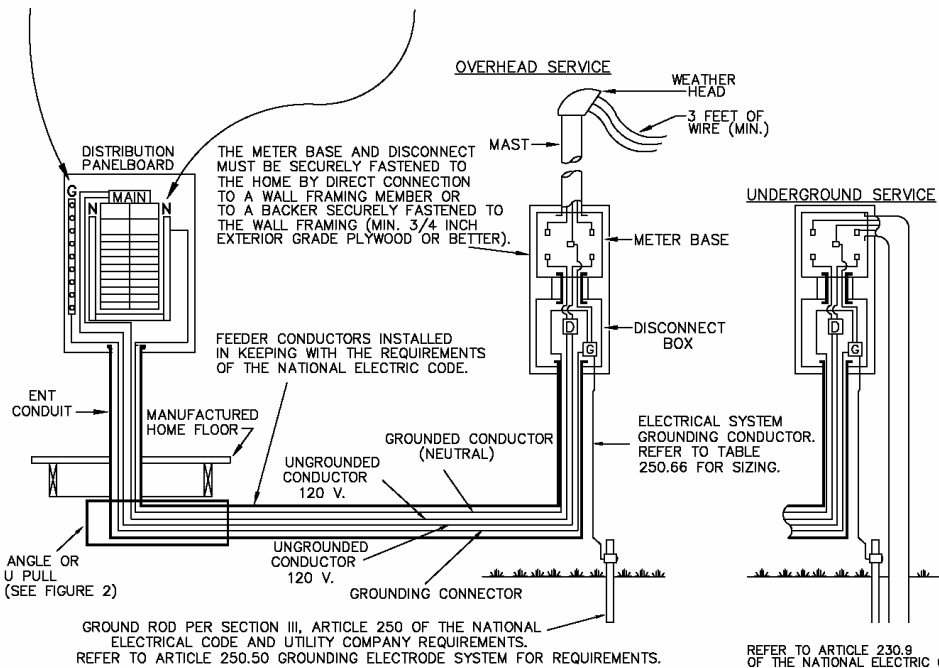

FIGURE-3

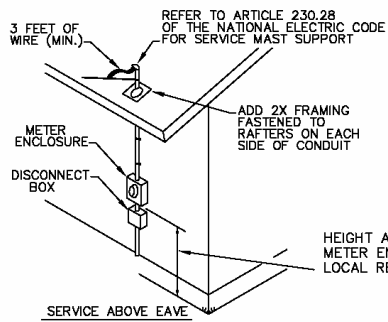

FIGURE-4

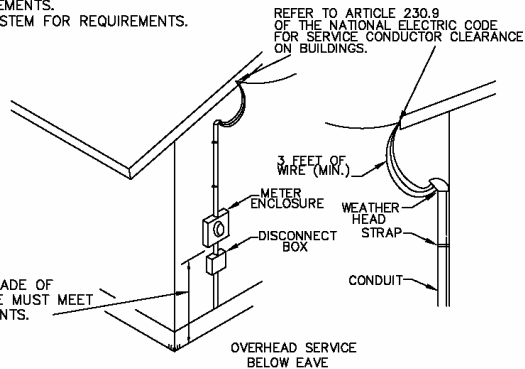

FIGURE-5

# INDEX

## INTRODUCTION

1-1 A SPECIAL WORD TO THE HOMEOWNER.....	1
1-2 NOTICE TO THE HOMEOWNER.....	1

## IMPORTANT AIR QUALITY INFORMATION

2-1 LIMITER AIR CHANGE AND LIMITED AIR VOLUME.....	2
2-2 AIR POLLUTANTS.....	2
2-3 IMPORTANT HEALTH NOTICE.....	2
2-4 ATTENTION HOMEOWNERS.....	2

## WARRANTY & DISPUTE RESOLUTION

3-1 WARRANTY.....	3
3-2 HUD DISPUTE RESOLUTION PROGRAM.....	6

## EXTERIOR MAINTENANCE

4-1 ROOF.....	8
4-2 METAL ROOF AND METAL ROOF.....	8
4-3 SHINGLELED ROOF.....	8
4-4 EXTERIOR FINISHES AND THEIR CARE.....	9
4-5 WINDOWS AND DOORS.....	9
4-6 PROPER ALIGNMENT.....	9
4-7 BOTTOM BOARD CLOSURE.....	10
4-8 PORCHES AND DECKS.....	10
4-9 STEEL FRAME ASSEMBLY.....	10
4-10 GROUND MOISTURE CONTROL.....	10
4-11 ATTACHMENTS.....	11

## INTERIOR MAINTENANCE

5-1 WALLS.....	11
5-2 CABINETS.....	11
5-3 TUB AND LAVATORIES.....	11
5-4 FURNITURE.....	11
5-5 COUNTER TOPS.....	11
5-6 DRAPES AND SPREADS.....	11
5-7 LOOSE MOULDING.....	12
5-8 FLOORS.....	12
5-9 CEILINGS.....	12
5-10 WATER CLOSETS.....	12
5-11 WHIRLPOOL BATH TUBS.....	13
5-12 CONDENSATION.....	13
5-13 TO SUMMERIZE.....	14
5-14 WINTER PRECAUTIONS.....	14
5-15 INTERIOR VENTILATION.....	14
5-16 MOISTURE AND YOUR HOME ENVIRONMENT.....	15

## HOME SAFETY FEATURES

6-1 EGRESS WINDOWS.....	15
6-2 SMOKE ALARM.....	15
6-3 GFCI CIRCUIT BREAKER.....	16
6-4 FIRE PROTECTION.....	16
6-5 VENTED KITCHEN.....	16
6-6 GROUND ANCHORS.....	16
6-7 ELECTRICAL SYSTEM.....	16
6-8 FUEL SYSTEMS.....	18

6-9 HEATING AND COOLING SYSTEMS.....	19
6-10 WATER AND DRAINAGE SYSTEMS.....	20
6-11 MAJOR APPLIANCES AND WATER HEATERS.....	20
6-12 SHUT OFF VALVES.....	22
6-13 EXIT DOORS.....	22
6-14 HIGH WIND PRECAUTIONS.....	22
6-15 AIR INTAKES.....	22

**INSURANCE**

7-1 GENERAL.....	22
7-2 COMPREHENSIVE PHYSICAL DAMAGE.....	23
7-3 LIABILITY INSURANCE.....	23
7-4 CREDIT LIFE INSURANCE.....	23
7-5 CREDIT ACCIDENT AND HEALTH INSURANCE.....	23
7-6 OTHER CONSIDERATIONS.....	24

**SPECIAL INFORMATION**

8-1 INSTALLATION PROCEDURES.....	24
8-2 SETTLING.....	24
8-3 SKIRTING.....	24
8-4 MOVING.....	25
8-5 ROAD GEAR INSPECTION.....	25
8-6 REINSTALLATION OF ROAD GEAR.....	26
8-7 PACKING.....	26
8-8 OVERLOADING.....	26
8-9 ROUTING.....	27
8-10 WARRANTIES AND WARRANTY SERVICE.....	27
8-11 PREVENTIVE MAINTENANCE.....	27
8-12 THE DATA PLATE.....	28
8-13 ATTIC STORAGE SPACE.....	28
8-14 U.S. DEPARTMENT OF HOUSING AND URBAN DEVELOPMENT.....	28
8-15 STATE ADMINISTRATIVE AGENCIES (SAA).....	29
8-16 OTHER INFORMATION.....	30
8-17 YOUR LOCAL SERVICE REFERENCES.....	31
8-18 OWNERS PREOCCUPANCY CHECK LIST.....	33
8-19 SEASONAL MAINTENANCE AND CARE.....	33



This page intentionally left blank.

